



(12) **EUROPEAN PATENT SPECIFICATION**

(45) Date of publication and mention of the grant of the patent: 30.07.1997 Bulletin 1997/31
(51) Int. Cl.⁶: B41M 3/14, G03C 5/08, G03C 8/42, G03C 8/28, G03C 8/52

(21) Application number: 93203473.9

(22) Date of filing: 10.12.1993

(54) **Security document having a transparent or translucent support and containing interference pigments.**

Sicherheitsdokument mit einem durchsichtigen oder durchscheinenden Träger und mit darin enthaltenden Interferenzpigmenten

Document de sécurité ayant un support transparent ou translucide et contenant des pigments d'interférence

(84) Designated Contracting States:
BE CH DE ES FR GB LJ NL

• De Baets, Daniel
de Berlaimontaan 14, B-1000 Brussel (BE)

(43) Date of publication of application:
14.06.1995 Bulletin 1995/24

(56) References cited:
EP-A- 0 317 514 DE-A- 3 810 015
DE-C- 62 053 FR-A- 2 429 292
GB-A- 202 702 GB-A- 2 035 587

(73) Proprietors:
• AGFA-GEVAERT
naamloze vennootschap
2640 Mortsel (BE)
• NATIONALE BANK VAN BELGIE N.V.
1000 Brussel (BE)

• PATENT ABSTRACTS OF JAPAN vol. 8, no. 210 (M-328)(1647) 26 September 1984 & JP-A-59 098 891 (DAINIPPON INSATSU) 7 June 1984
• PATENT ABSTRACTS OF JAPAN vol. 10, no. 115 (M-474)(2172) 30 April 1986 & JP-A-60 244 588 (KAZUHIRO NARA) 4 December 1985
• PATENT ABSTRACTS OF JAPAN vol. 10, no. 191 (M-495)(2247) 4 July 1986 & JP-A-61 035 985 (DAINICHI SEIKA) 20 February 1986

(72) Inventors:
• Vermeulen, Leon
Septestraat 27, B-2640 Mortsel (BE)

EP 0 657 297 B1

Note: Within nine months from the publication of the mention of the grant of the European patent, any person may give notice to the European Patent Office of opposition to the European patent granted. Notice of opposition shall be filed in a written reasoned statement. It shall not be deemed to have been filed until the opposition fee has been paid. (Art. 99(1) European Patent Convention).

Description

1. Field of the Invention

5 The present invention relates to transparent or translucent security documents that can be verified on their authenticity and are protected against counterfeiting by photo-copying.

2. Background of the Invention

10 Security documents that must be verifiable on their authenticity are e.g. all kinds of identification documents such as passports, visas, identity cards, driver licenses, bank cards, credit cards, security entrance cards, and further value-documents such as banknotes, shares, bonds, certificates, cheques, lottery tickets and all kinds of entrance tickets such as airplane tickets and railroad season-tickets.

15 Nowadays, by the availability of markedly improved black-and-white and color copiers it becomes more and more easy to copy documents at high quality hardly to distinguish from the originals.

To protect the above mentioned documents against fraudulent alterations and reproduction by photo-copying different techniques are used such as the melt-laminating or glueing thereto of preprinted plastic overlayers; the printing with special inks; the application of coatings or layers for example loaded with magnetic or fluorescent pigments; coloring or metalizing the substrate of the documents; incorporating holograms; applying fine line printing, watermarks, fibers, security threads, light diffraction marks, liquid crystal marks and/or substances called nacreous, iridescent or interference pigments.

In a particular case disclosed in US-P 4,151,666 light-transmissive pigments serving as diffuse reflectors are applied by printing to form a verification pattern in a laminated identification card (I.D. card). In the specification of the same US-P the use of nacreous pigments in verification patterns has been described. Nacreous pigments, also called 25 pearlescent pigments have light-reflection characteristics that change as a function of the viewing or copying angle. The effect of changing color with viewing angle makes that nacreous pigments represent a simple and convenient matter to build in a verification feature associated with a non-copyable optical property.

Interference pigments are in the form of light-reflecting crystal platelets of appropriate thickness to produce color by interference. These pigments exhibit a color play that verges on iridescence and under a given angle of reflection will 30 allow only the copying of a single color, whereas other colors appear under different angles of reflection, in other words these pigments show another color to the human eye depending on the observation angle. High nacreous luster is accompanied by high specular reflectance.

In most light interference pigments the transmission color is generally the complement of the reflection color.

35 Observed in transmission, some particular light interference pigments having more pronounced covering aspect show a particular greyish color while observed in reflection mode they have a more pronounced color-shift effect due to their specific built up and composition.

Transmission color of light interference pigments is much weaker than reflection color, which color seen in the reflection mode is called hereinafter "normal" color. [ref. Number 2 in a series of Mearl Technical Bulletins "Nacreous (Pearlescent) Pigments and Interference Pigments by L.M. Greenstein Henry L. Mattin Laboratories Reprinted from 40 Pigment Handbook, Vol. I, Properties and Economics, 2nd Edition, Edited by Peter A. Lewis, (1988) by permission of John Wiley & Sons, Inc. The Mearl Corporation, 41 East 42nd Street, New York, N.Y. 10017, p. 5 and 6].

In interference, the reflection and transmission colors vary with angle of incidence. The reflection maximum and minimum shift to lower wavelengths as the angle of incidence increases (ref. the above mentioned Mearl Technical Bulletin, p. 8. Variation in color with angle of incidence and observation is referred to as geometric metamerism or goniochromatism [ref. Johnston, R. M. Color Eng., 5(3), 42-47, 54 (1967) and Hemmendinger, H. and Johnston R.M. "A 45 Goniospectrophotometer for Color Measurements" in Color 69 (M. Richter. ed). Musterschmidt, Göttingen, Germany (1970)].

3. Objects and Summary of the Invention

50 It is an object of the present invention to provide a security document having a transparent or translucent support and containing through the presence of light interference pigments a verification feature that can not be copied by photographic techniques and wherein there is no need for specialized devices or conditions to verify the document on its authenticity.

55 It is a particular object of the present invention to provide a security document having a transparent or translucent support and containing at least one image or pattern in conjunction with interference pigments providing special effects that can not be copied photographically.

It is a special object of the present invention to provide a security document having a transparent or translucent support and comprising a layer including a photographically obtained portrait in conjunction with different light interfer-

ence pigments that allow easy verification by the naked eye of the security document involved.

Other objects and advantages of the present invention will become clear from the further description, drawings and examples.

In accordance with the present invention there is provided a security document which contains at least one layer and a transparent or translucent support and at least one image or pattern serving for identification purposes, characterized in that said document contains at least one light interference pigment distributed uniformly or patternwise in or on at least one layer of said document and/or contains said pigment in said support.

By "transparent or translucent support" in the document according to the present invention has to be understood a support having a visible light-blocking capacity less than 80 %, preferably less than 50 %, not being excluded supports that are inherently colored or have obtained a color by incorporation of colorants.

4. Description of the drawings

Fig. 1 represents a schematic sectional drawing of a security document according to the present invention wherein light interference pigments A are present uniformly in a layer on one side of a transparent support TS and light interference pigments B different in color with respect to pigments A are present uniformly in a layer on the other side of said support and said document contains a photographically obtained image PH in the layer containing said pigments A.

Fig. 2 represents a schematic sectional drawing of a security document according to the present invention wherein light interference pigments A are present uniformly on one side of a transparent support TS and light interference pigments B different in color with respect to pigments A are present uniformly on the other side of said support, wherein the pigments A have underneath a pattern printed with "common" light reflecting pigments R having no light interference properties.

Fig. 3 represents a schematic sectional drawing of a security document according to the present invention wherein at one side of a transparent support TS a layer containing light interference pigments A has on top a printed pattern containing common light-reflecting pigments R. At the other side of said support a printed pattern containing said normal pigments R is overprinted with a pattern containing light interference pigments B.

Fig. 4 represents a schematic sectional drawing of a security document according to the present invention wherein patterns containing light interference pigments A at one side of a transparent support TS are printed over (1) a pattern containing "common" light reflecting pigments R1 of which the color is complementary to the color of said pigments A when seen with reflected light, (2) a pattern comprising "common" light reflecting pigments R1 mixed with colored fluorescent or phosphorescent pigments or dyes RF, and (3) patterns containing solely fluorescent or phosphorescent dyes that may be white by inspection with visible light but emit colored light when exposed to ultraviolet light. At the other side of said support TS light interference pigments B are printed over (1) an opaque pattern containing metallic pigments (aluminium or bronze flakes) M, (2) a pattern comprising metallic pigments M mixed with "common" light reflecting pigments R2 having a color complementary to the color of said light interference pigments B when seen with reflected light, and (3) a pattern comprising solely light reflecting pigments R2 having a color complementary to the color of said light interference pigments B when seen with reflected light.

5. Detailed Description of the Invention

A layer and/or pattern containing said light interference pigments (same or different) may be present at both sides of said transparent or translucent support.

The security document according to the present invention may contain in the same patterns and/or layer mixtures of different light interference pigments.

In a particular embodiment the support itself contains said light interference pigments and is produced e.g. by extruding a melt of a thermoplastic resin having homogeneously distributed therethrough one or more of said light interference pigments, or is produced by coating a resin solution having said pigment(s) dispersed therein followed after coating by the evaporation of the solvent(s) used.

An image or pattern present in said document may be formed by printing techniques including non-impact printing techniques and photographic techniques by which is understood herein that a visually inspectable image has been obtained in said document via a light-pattern transmitted or reflected by an original.

The document of the present invention by the presence of said interference pigments (including mixtures of said pigments) has at least in certain areas a different color when viewed with light transmitted by the document in comparison with light reflected by the document, and has at least in certain areas a different color when viewed in transmission mode from front or rear side. These properties form verification features that cannot be copied with common color copying machines and allow easy verification by the naked eye of the security document involved.

Preferred light interference pigments are titanium dioxide-coated mica or other metal-oxide coated pigments in which the metal oxide has preferably a refractive index comparable with the refractive index of TiO_2 , e.g. ZrO_2 , Fe_2O_3 or Cr_2O_3 .

The platelets of metal oxide coated mica pigments have three layers in such a way that on each of the broad faces of the mica platelets a very thin coating of metal oxide is present.

The more brilliant interference pigments approach metallic luster, an effect that is enhanced by the presence of absorption colorants. TiO_2 -mica readily lends itself to incorporation of absorption colorants. Ferric oxide (Fe_2O_3) added to the TiO_2 layer, for example imparts a yellow color which in conjunction with a yellow interference color creates gold. When Fe_2O_3 is used in place of TiO_2 as the oxide coating on mica, these pigments have a yellow-red absorption color because of the inherent color of the Fe_2O_3 . They range from bronze to deep copper-red and have a metallic luster.

The preparation of such kind of pigments is described in the already mentioned bulletin "Nacreous (Pearlescent) Pigments and Interference Pigments", p. 3-4.

Mica pigments serving as a substrate of the interference coatings are a group of hydrous aluminum silicate minerals with platy morphology and perfect basal (micaceous) cleavage. Examples of suitable micas are e.g. muscovite $\text{KAl}_2(\text{AlSi}_3\text{O}_{10})(\text{OH})_2$, paragonite $\text{NaAl}_2(\text{AlSi}_3\text{O}_{10})(\text{OH})_2$, phlogopite $\text{K}(\text{Mg,Fe})(\text{AlSi}_3\text{O}_{10})(\text{OH})_2$, biotite $\text{K}(\text{Fe,Mg})(\text{AlSi}_3\text{O}_{10})(\text{OH})_2$ and lepidofite $\text{K}(\text{Li,Al})_{2.5-3.0}(\text{Al}_{1.0-0.5}\text{Si}_{3.0-3.5}\text{O}_{10})(\text{OH})_2$ etc.

Details about the application of metal and/or metal oxide coatings on the mica platelets are further given in US-P 3,087,827, 4,434,010 and 5,059,245 and in published EP-A-45 851, EP-A-313 280, DE-A-11 65 182, DE-A-32 37 264, DE-A-38 25 702 and DE-A-36 17 430 and DE-OS 41 41 069.

In a preferred embodiment according to the present invention interference pigments having a composition as described in published German patent application DE-OS 41 41 069 are used. Said interference pigments, called "Glanzpigmente" according to said DE-OS are composed of silicate platelets coated with either :

- A) a first layer of highly refractive metal oxide, and
 B) a second black layer essentially consisting of metallic iron, molybdenum and/or wolfram, or coated with :

- A) a first layer of highly refractive metal oxide, and
 B) a second black layer essentially consisting of carbon or metal, and
 C) a third layer of highly refractive metal oxide.

By the presence of a semi-transparent carbon layer said platelets have a high chemical resistance. The carbon layer is obtained by thermal decomposition of oxygen-containing hydrocarbon compounds which for each two carbon atoms contain at least one oxygen atom e.g. as in carbohydrates such as sorbitol.

The metal layer B) can be formed in a medium of inert gas from in-gas-phase-decomposable metal compounds, e.g. metal carbonyl compounds, and the metal oxide layers A) and C) are formed by decomposition in gas phase of volatile metal compounds in the presence of oxygen water vapour or mixtures thereof.

The first layer A) consists e.g. of the oxides of titanium, zirconium, tin and/or iron.

Mica platelets double-side coated with one or more metal oxide layers for use as interference pigments are commercially available e.g. under the tradenames IRIODINE (E. Merck, Darmstadt), FLONAC (Kemira Oy, Pori, Finland), MEARLIN (The Mearl Corporation, New York, U.S.A.) and PALIOSECURE (BASF, Germany). Under these tradenames interference pigments showing violet, red, green, yellow and blue colors in reflected light at 90° are available on the market.

Holding an interference pigment-coated transparent support at 90° in a white light beam the transmitted light may be greyish-yellow to slightly brown which is a totally different color when seen in reflection (the main color). Such effect was seen as well in hydrophilic colloid coatings containing said pigments as in hydrophobic varnish layers. These differences of color in reflected and transmitted light cannot be photo-copied and form an easily detectable verification feature.

Moreover, looking at a coated blue interference pigment layer under different reflection angles the a blue color seen under a reflection angle of 90° will at a reflection angle smaller than 45° turn into yellow, green interference pigments obtain under these circumstances a greyish shade, whereas the violet and red pigments show a brownish-grey hue. In transparency inspection mode blue interference become brown yellow, magenta interference pigments turn green, and the green ones turn magenta.

Preferred interference platelet-type pigments for use according to the present invention have a largest surface diameter preferably between 5 and 200 μm and more preferably of 25 μm to 30 μm . The thickness of the platelet-type interference pigments is preferably between 0.1 μm and 0.6 μm and more preferably between 0.2 μm and 0.4 μm .

In order to obtain special verification effects under ultraviolet light exposure the interference pigments can be used in admixture with fluorescent or phosphorescent substances and optical brightening agents.

By way of example the light interference pigments A of the above drawings are blue light interference pigments such as PALIOSECURE (tradename of BASF - Germany) pigment code EC 1408 which shows when seen in reflection mode a vivid blue color. Seen in reflection their color changes in shade by changing the observation angle. When observed in transmission through said transparent substrate said blue pigments change their hue and the color becomes complementary to blue, i.e. yellow, slightly darkened with a brown shade that is probably due to very small

impurities. A yellow light interference pigment such as IRIODINE (tradename of MERCK - Germany) pigment code 9331 has when observed in reflection mode a yellow color; seen in transmission the color of that pigment becomes complementary in color, i.e. blue. This is in accordance with the general property of light interference pigments of changing their color complementarity when changing their mode of viewing going from reflection to transmission mode.

5 Tests have been carried out in printing a security pattern on a transparent substrate in such a way that one part of a printing pattern was printed with blue light interference pigment (e.g. PALJOSECURE EC 1408 or FD 4187 of BASF - Germany) and another part was printed using a yellow interference pigment (e.g. IRIODINE 9231 of MERCK - Germany). By changing the viewing conditions from transmission to reflection mode the differently printed parts changed their color complementarity, so that the colors became inverted, which is as already been said, an effect that cannot be
10 reproduced photographically by color copying machines. Common xerographic copying machines make prints against a white background (the color of the side of the cover of the machine contacting the original is white light reflecting). The light interference pigments that face the light source have high reflectance and show their normal color, whereas the "complementary" color is reproduced with transmitted light reflected by said cover.

Said property provides a strong security feature which makes e.g. that when a yellow light interference pigment background is surrounding an information pattern printed with a blue light interference pigment pattern a copying machine operating with transmitted light (that is reflected by its white cover) will provide a copy that has the printed information in yellow surrounded by a blue background which is the complementary in color from what can be seen directly in reflected light not passing through the document.

Further it has been found by us that when copying a transparent document printed with light interference pigments and overprinted with a fine guilloche design with common light reflecting pigment being no light interference pigment, the color of the guilloche pattern in the photocopy is different whether (1) the copy is made with the front side of the transparent document (original) directed towards the light source of the copying machine or (2) the copy is made with the light of said source directed through the rear of the transparent document towards the information pattern and image background at the front side receiving reflected light from the white light reflecting cover of the machine.

15 In the first case said "common" pigments contained in the guilloche pattern are reproduced with their inherent color and the light interference pigments are reproduced in the transmission mode in their complementary colors.

In the second case the photocopying machine does not see in reflected light the pattern of said "common" light reflecting pigments that have been printed on top of the light interference pigments so that they are not reproduced anymore, while the light interference pigments remain copied in their complementary color.

20 The "common" light reflecting pigments can be printed underneath or above the light interference pigments.

Thus, when in the above combination of information pattern and background a fine guilloche design having e.g. lines 3 microns wide, is printed with common yellow colored pigments (yellow light reflecting pigments) being no light interference pigments the differences between the copy and the original will become still more outspoken in that the color of the guilloche lines will be reproduced correctly but will not be detectable against the yellow pattern of light interference pigments seen by the copying machine.

25 In the embodiment illustrated in Fig. 3 the light reflecting pigments R can show a rainbow effect (are iridescent) wherein one of their rainbow colors has the same hue as the color of the light interference pigments being printed on top.

In the embodiment illustrated in Fig. 4 the light reflecting colors showing rainbow effect (often used in security documents) are used in a printing ink containing metallic powder (e.g. aluminium or bronze). Printed underneath the light interference pigments the metallic powder being opaque blocks light and prevents copying of information present on the other side of the transparent support. Opacifying front and back images may be printed on top and/or underneath the patterns containing light interference pigments. The printing on both sides of the transparent support may be in perfect front/back registration using a therefor adapted printing machine such as a "Simultan Press" which is known for printing
40 security documents.

When the design of the document is arranged in such a way that the light interference pigment pattern does not cover completely the printing pattern of the light reflecting pigments underneath, the observation in reflective mode shows the light reflecting pigments in their own color on the front or rear side of the document in the non-covered zone only. In the covered zone the light interference pigments show in reflective mode their main color.

50 On inspection in transmission mode (holding the document to the light) or copying with transmitted light the patterns of common light-reflecting pigments from front and rear side of the document are added (combined) and may form an uninterrupted area in the field of light interference pigments showing their own complementary color or combination of said complementary colors in overlapping zones, which may result in a continuous grey area where the complementary colors each represent a complementary part of the visible spectrum, as is the case e.g. by having in congruency a zone containing yellow-reflecting light interference pigments and a zone containing blue-reflecting light interference pigments.
55

Light interference pigments may be mixed with fluorescent or phosphorescent pigments without blocking the light emitted thereby. Light interference pigments have always some transparency together with their high specular reflectance.

According to one embodiment the above mentioned photographically obtained image or pattern is produced by means of a black-and-white or colour developed photosensitive silver halide directly in a light-sensitive material itself or in a non-light-sensitive image receiving material having a transparent support.

According to another embodiment the above mentioned photographically obtained image or pattern is produced by means of a non-impact printing technique in which analog or digital input signals for controlling the printing of said image or pattern stem from light-information originating from a visible original, which light-information may be transformed into electrical signals that can be transduced and stored, e.g. on magnetic tape or optical disk. The visible original may be an object or living being or an already formed photograph of these.

A survey of non-impact printing techniques such as electro(photo)graphic printing, ink jet printing, photochemical printing and thermal transfer printing is given by Jerome L. Johnson in "Principles of Non Impact printing" Palatino Press - Irvine, California U.S.A. (1986).

In accordance with an embodiment according to the present invention there is provided a document including a photographically obtained image or pattern and uniformly distributed interference pigments of a particular color are present in the document in combination with a printed pattern containing interference pigments of a color different from the color of the uniformly distributed interference pigments.

In accordance with another embodiment according to the present invention there is provided a document including a photographically obtained image or pattern and having at each side of its transparent or translucent support a layer wherein interference pigments are distributed uniformly, and wherein said layers at opposite sides of said support have a different color by the presence of different interference pigments.

In accordance with a further embodiment according to the present invention there is provided a document wherein uniformly distributed interference pigments are present in combination with pattern-wise printed colored common light-reflecting pigments or dyes or white light reflecting pigments, e.g. TiO_2 . The color of the interference pigments under the copying angle is preferably the same as the color of said printed light-absorbing substances preventing thereby successful photocopying of the printed information that remains still readable by the human eye under another observation angle.

According to still another embodiment in a document of the present invention a pattern of printed interference pigments is present underneath and/or on top of a layer or support having a color substantially the same as the color of said pattern containing said interference pigments when seen in reflection or transmission mode.

According to an embodiment in the security document according to the present invention different interference pigments are present uniformly each in a different layer at opposite sides of said support and at least one of said layers has underneath and/or on top a pattern containing common light-reflecting pigments and/or dyes having no light interference properties, and having preferably a color substantially the same as the color of at least one of the interference pigments when seen in reflection or transmission mode.

According to another embodiment in the security document according to the present invention at least one pattern containing common light-reflecting pigments and/or dyes is present which pattern is at least partly covered with a pattern containing interference pigments.

According to a further embodiment in the document according to the present invention the support has been coated directly by sputtering with a thin metal oxide layer or has been coated with said metal oxide layer on top of a coating or pattern of said light interference pigments and/or coating or pattern of light reflecting pigments having no light interference properties taking care that the thus coated metal oxide layer has substantially the same or color complementary to the color of said patternwise applied pigments.

According to a special embodiment the document according to the present invention has on the front and/or rear side of its support underneath and/or on top thereof uniformly or patternwise applied interference pigments in the form of a printed guilloche line pattern with rainbow effect, containing therefor light reflecting pigments showing that effect so as to have one or more of the rainbow colors the same as the normal or complementary color of said light interference pigments. In a particular case said one or more of the rainbow colors is obtained by printing metallic pigments.

In another embodiment fluorescent or phosphorescent pigments have been mixed with said light interference pigments and/or with said light reflecting pigments giving said rainbow effect to the guilloche pattern or said rainbow effect is obtained by printing a transparent varnish-loaded with a fluorescent or phosphorescent pigment.

According to a still further embodiment the document according to the present invention contains (a) bi-fluorescent pigment(s) that is (are) mixed with one of said light reflecting pigments and/or mixed with said light interference pigments whereby when exposed to ultraviolet light said fluorescent pigment(s) show(s) light of two different wavelength ranges one of which is different from the wavelength range of the colors of said light reflecting and interference pigments when these are observed under visible light conditions and the other corresponds with the normal or complementary color of said interference pigments.

In a particular embodiment a guilloche pattern with rainbow effect is printed in perfect see-through print register on the front and rear side of the support; the light reflecting pigments showing rainbow effect printed at one side have complementary color with respect to the pigments printed, but have at one side a color the same as the normal color of said light interference pigments, and wherein parts of said guilloche pattern at either side cover at least partly a photograph

or printed pattern or complete a printed pattern.

In a particularly interesting embodiment the document according to the present invention contains printed patterns at least partly covering each other and said patterns each contain (a) different light interference pigment(s) the construction and composition of which is such that they show a different color shift when viewed under the same observation angle, and wherein the printed pattern most remote from the observer has higher covering power than the pattern printed thereon which is more transparent, hereby obtaining a document that shows in the overlapping pattern area a continuously changing color shift by changing gradually the observation angle.

A layer containing uniformly distributed light interference pigments may be applied by coating a coating liquid containing said pigments in dispersed form and a dissolved binding agent or containing said pigments dispersed together with a binding agent in the form of a latex. After coating the solvent or dispersing liquid, e.g. water, is removed by evaporation. Any coating technique for the application of thin liquid layers may be used as is known e.g. from the field of the manufacture of photographic silver halide emulsion layer materials, e.g. doctor blade coating, gravure roller coating, meniscus coating, air knife coating, slide hopper coating and spraying.

According to a special coating technique the light interference pigments are applied in a radiation-curable binder or binder system wherein e.g. monomers act as solvent for polymers or prepolymers as described e.g. in published EP-A 0 522 609, so that after coating of the liquid coating composition no solvent has to be evaporated.

In accordance with a particular embodiment uniformly distributed interference pigments are applied in a layer that is transferred by a stripping-off procedure to build the document of the present invention. Such procedure is described in published EP-A 0 478 790 but is applied therein for controlling the whiteness of an image present on a permanent support using for the stripping-off and transfer procedure a temporary support coated with a wet-strippable non-photosensitive layer containing fluorescent whitening agent(s) in a hydrophobic colloid binder.

According to a special embodiment the light interference pigments are applied in the form of a pigment-transfer-foil wherefrom by hot transfer the pigments are transferred uniformly onto the substrate of the security document.

Still another coating technique suited for uniformly applying said pigments is by dry powder-spraying optionally on a hot-melt resin layer wherein they are impregnated by pressure and heat. On top of the pigments an adhesive, e.g. wax may be applied to improve adherence to the selected substrate. That substrate may have hydrophilic or hydrophobic surface properties.

Spray-coating may be applied for covering the whole surface of the substrate or only a part thereof producing "light interference rainbow-effects". By using varying mixtures of different interference pigments the intensity of one color can be made to decrease gradually while an increasing color intensity of another pigment comes up. The human eye will see the rainbow effect varying according to the perception angle and will recognize the basic color of each of the sprayed pigments, but a photocopier operating with a fixed copying angle will only reproduce, say a single yellowish-brown color and not the colors of the interference pigments that can be seen under different inspection angles.

The interference pigments can be used for pigmenting a commercial coating varnish which may then be used for pre-coating a security document substrate, e.g. opaque resin film or paper. The coating may proceed with common varnishing or impregnation machinery instead of using printing presses.

As already mentioned herein the uniformly applied interference pigments are advantageously combined with image-wise or pattern-wise applied interference pigments of another color.

The image-wise or pattern-wise application of interference pigments proceeds e.g. by printing with an ink containing said pigments. Suited printing processes are e.g. planographic offset printing, gravure printing, intaglio printing, screen printing, flexographic printing, relief printing, tampon printing, ink jet printing and toner-transfer printing from electro(photo)graphic recording materials.

For use in printing on hydrophilic layers or substrates the ink contains for example a 15 to 20 % by weight mixture of the interference pigments in a solution of cellulose nitrate in a polyethylene ether. Such ink has a good adherence on hydrophilic colloid layers such as gelatin-containing layers used in DTR-recording materials. Said ink is advantageously applied with a commercial screen press using a polyester screen with a 77 and 55 mesh. The interference colors gradually appear on drying the ink.

Thus applied ink patterns on a hydrophilic image-receiving layer for DTR-image production remain unchanged during DTR-processing.

The presence of the light interference pigments in one of the layers of the opaque security document does not affect the possibility to print thereon further graphic or alpha-numerical information by any known printing technique.

For easy visual verification the light interference pigments are present preferably in a security document in a coverage of 0.3 g/m² to 10 g/m² and more preferably in a coverage between 0.7 g/m² and 3 g/m².

The printing of a light interference pigment-containing pattern may proceed on a substrate already covered e.g. by a hologram, light-diffraction pattern, metallic pattern that can be viewed through the printed pattern so that the properties of the interference pigments are added thereto.

The printed pattern containing interference pigments forms no obstacle for a good adherence with laminated plastic resinous covering material. By proper selection of the binder of the ink it can be co-melted with the resin material laminated thereto.

According to a particular embodiment the light interference pigment-containing ink is applied on a temporary support, e.g. polystyrene support, wherefrom the ink layer can be stripped off and transferred to a permanent support, e.g. a glued and preprinted substrate of a security document. The ink layer, applied overall or pattern-wise, after leaving the temporary support covers underlying pre-printed data on the permanent support. For preventing fraudulent copying these data have the same color as the interference pigment layer when seen under the copying angle. Insufficient image contrast is available so that copying of the pre-printed data is no longer possible. By applying a dried interference pigment-containing ink layer that is translucent the underlying data can be visually inspected therethrough by altering the perception angle.

In accordance with the preceding embodiment a security document according to the present invention, e.g. serving as I.D. card, is preferably in the form of a laminate in which the information-containing layer(s) are sealed between protective resinous sheets. I.D. card laminates may be built up as described e.g. in US-P 4,101,701, US-P 4,762,759, US-P 4,902,593, published EP-A 0 348 310 and published EP-A 0 462 330. By lamination tamper-proof documents are produced which do not allow the opening of the laminate without damaging the image contained therein. The destruction of the seal will leave visual fraude traces on the security document.

In accordance with a first mode in the security document according to the present invention a black-and-white photograph in the form of a silver image is formed by the silver salt diffusion transfer process, called herein DTR-process. According to said process dissolved silver halide salt is transferred imagewise in a special image receiving layer, called development nuclei containing layer, for reducing therein transferred silver salt, said development nuclei containing layer contains itself and/or in an overlaying and/or an underlaying layer uniformly distributed therein said interference pigments.

The light interference pigments may be present either in the image-receiving layer itself and/or in a waterpermeable top layer and/or in a subbing layer covering the support.

The presence of a dried water-impermeable ink pattern on the image-receiving layer blocks DTR-image formation. Thereby it is possible to arrange e.g. fine line patterns such as guilloches in the photograph creating that way an additional verification feature.

The principles of the DTR-process are described in U.S. patent No. 2,352,014 of André Rott, issued June 20, 1944. According to said process silver complexes are image-wise transferred by diffusion from a silver halide emulsion layer to an image-receiving layer, where they are converted, in the presence of development nuclei, into a silver image. For this purpose, an image-wise exposed silver halide emulsion layer is developed by means of a developing substance in the presence of a so-called silver halide solvent. In the exposed parts of the silver halide emulsion layer the silver halide is developed to metallic silver so that it cannot dissolve anymore and consequently cannot diffuse. In the non-exposed parts of the silver halide emulsion layer the silver halide is converted into soluble silver complexes by means of a silver halide complexing agent, acting as silver halide solvent, and said complexes are transferred by diffusion into an image-receiving layer being in waterpermeable contact with said emulsion layer to form by the catalytic action of said development nuclei, in so-called physical development, a silver-containing image in the image-receiving layer.

More details on the DTR-process can be found in "Photographic Silver Halide Diffusion Processes" by A. Rott and E. Weyde, Focal Press, London, New York (1972).

In accordance with a second mode in the opaque security document according to the present invention a color photograph in the form of one or more dye images is formed by the dye diffusion transfer process (dye DTR-process) wherein the image-wise transfer of dye(s) is controlled by the development of (a) photo-exposed silver halide emulsion layer(s), and wherein dye(s) is (are) transferred imagewise in a special image receiving layer, called mordant layer, for fixing the dyes, said mordant layer and/or an overlaying and/or an underlaying layer containing uniformly distributed therethrough said interference pigments.

Dye diffusion transfer reversal processes are based on the image-wise transfer of diffusible dye molecules from an image-wise exposed silver halide emulsion material into a waterpermeable image-receiving layer containing a mordant for the dye(s). The image-wise diffusion of the dye(s) is controlled by the development of one or more image-wise exposed silver halide emulsion layers, that for the production of a multicolor image are differently spectrally sensitized and contain respectively a yellow, magenta and cyan dye molecules. A survey of dye diffusion transfer imaging processes has been given by Christian C. Van de Sande in Angew. Chem. - Ed. Engl. 22 (1983) n° 3, 191-209 and a particularly useful process is described in US-P 4,496,645.

For use in dye diffusion transfer photography the type of mordant chosen will depend upon the dye to be mordanted. If acid dyes are to be mordanted, the image-receiving layer being a dye-mordanting layer contains basic polymeric mordants such as polymers of amino-guanidine derivatives of vinyl methyl ketone such as described in US-P 2,882,156, and basic polymeric mordants and derivatives, e.g. poly-4-vinylpyridine, the metho-p-toluene sulphonate of poly-2-vinylpyridine and similar compounds described in US-P 2,484,430, and the compounds described in the published DE-A 2,009,498 and 2,200,063. Other mordants are long-chain quaternary ammonium or phosphonium compounds or ternary sulphonium compounds, e.g. those described in US-P 3,271,147 and 3,271,148, and cetyltrimethylammonium bromide. Certain metal salts and their hydroxides that form sparingly soluble compounds with the acid dyes may be used too. The dye mordants are dispersed or molecularly divided in one of the usual hydrophilic binders in the

image-receiving layer, e.g. in gelatin, polyvinylpyrrolidone or partly or completely hydrolysed cellulose esters.

In US-P 4,186,014 cationic polymeric mordants are described that are particularly suited for fixing anionic dyes, e.g. sulphinic acid salt dyes that are image-wise released by a redox-reaction described e.g. in published EP-A 0,004,399 and US-P 4,232,107.

5 The DTR process can be utilized for reproducing fine originals e.g. printed documents, as well as for reproducing continuous tone originals, e.g. portraits.

By the fact that the DTR-image is based on diffusion transfer of imaging ingredients the image-receiving layer and optionally present covering layer(s) have to be waterpermeable.

10 The reproduction of black-and-white continuous tone images by the DTR-process requires the use of a recording material capable of yielding images with considerable lower gradation than is normally applied in document reproduction to ensure the correct tone rendering of continuous tones of the original. In document reproduction silver halide emulsion materials are used which normally mainly contain silver chloride. Silver chloride not only leads to a more rapid development but also to high contrast.

15 In U.S. patent. No. 3,985,561, to be read in conjunction herewith, a light-sensitive silver halide material is described wherein the silver halide is predominantly chloride and this material is capable of forming a continuous tone image on or in an image-receiving material by the diffusion transfer process.

According to said U.S. patent a continuous tone image is produced by the diffusion transfer process in or on an image-receiving layer through the use of a light-sensitive layer which contains a mixture of silver chloride and silver iodide and/or silver bromide dispersed in a hydrophilic colloid binder e.g. gelatin, wherein the silver chloride is present 20 in an amount of at least 90 mole % based on the total mole of silver halide and wherein the weight ratio of hydrophilic colloid to silver halide, expressed as silver nitrate, is between 3:1 and about 10:1 by weight.

With these light-sensitive materials successful reproduction of continuous tone images can be obtained probably as a result of the presence of the indicated amounts of silver iodide and/or silver bromide and of the defined high ratio of hydrophilic colloid to silver halide.

25 According to U.S. patent No. 4,242,436 likewise to be read in conjunction herewith, the reproduction of continuous tone images can be improved by developing the photographic material with a mixture of developing agents comprising an o-dihydroxybenzene, e.g. catechol, a 3-pyrazolidinone e.g. a 1-aryl-3-pyrazolidinone and optionally a p-dihydroxybenzene, e.g. hydroquinone, the molar amount of the o-dihydroxybenzene in said mixture being larger than the molar amount of the 3-pyrazolidinone, and the p-dihydroxybenzene if any being present in a molar ratio of at most 5 % with respect to the o-dihydroxybenzene.

30 Suitable development nuclei for use in the above mentioned physical development in the image receiving layer are e.g. noble metal nuclei e.g. silver, palladium, gold, platinum, sulphides, selenides or tellurides of heavy metals such as Pd, Ag, Ni and Co. Preferably used development nuclei are colloidal PdS, Ag₂S or mixed silver-nickelsulphide particles. The amount of nuclei used in the image receiving layer is preferably between 0.02 mg/m² and 10 mg/m².

35 The image receiving layer comprises for best imaging results the physical development nuclei in the presence of a protective hydrophilic colloid, e.g. gelatin and/or colloidal silica, polyvinyl alcohol etc..

The transfer behaviour of the complexed silver largely depends on the thickness of the image-receiving layer and the kind of binding agent or mixture of binding agents used in the nuclei containing layer. In order to obtain a sharp image with high spectral density the reduction of the silver salts diffusing into the image receiving layer must take place 40 rapidly before lateral diffusion becomes substantial. An image-receiving material satisfying said purpose is described in US-P 4,859,566.

An image-receiving material of this type is very suitable for use in connection with the present invention and contains a water-impermeable support coated with (1) an image-receiving layer containing physical development nuclei and interference pigments dispersed in a waterpermeable binder and (2) a waterpermeable top layer free from development nuclei and containing a hydrophilic colloid, in such a way that :

(i) the total solids coverage of said two layers (1) and (2) is e.g. at most 2 g/m²,

(ii) in layer (1) the coverage of the nuclei is in the range of 0.1 mg/m² to 10 mg/m², and the coverage of binder is in the range of 0.4 to 1.5 g/m², and

50 (iii) in said top layer (2) the coverage of hydrophilic colloid is in the range of 0.1 to 0.9 g/m².

The coating of said layers proceeds preferably with slide hopper coater or curtain coater known to those skilled in the art.

65 According to a particular embodiment the nuclei containing layer (1) is present on a nuclei-free underlying hydrophilic colloid undercoat layer or undercoat layer system having a coverage in the range of 0.1 to 1 g/m² of hydrophilic colloid, the total solids coverage of layers (1) and (2) together with the undercoat being at most 2 g/m². In connection with this embodiment the nacreous pigments may be also be included in the undercoat layer or may be included therein instead of being present in the nuclei containing layer.

The undercoat optionally incorporates substances that improve the image quality, e.g. incorporates a substance

improving the image-tone or the whiteness of the image background. For example, the undercoat may contain a fluorescent substance, silver complexing agent(s) and/or development inhibitor releasing compounds known for improving image sharpness.

According to a special embodiment the image-receiving layer (1) is applied on an undercoat playing the role of a timing layer in association with an acidic layer serving for the neutralization of alkali of the image-receiving layer. By the timing layer the time before neutralization occurs is established, at least in part, by the time it takes for the alkaline processing composition to penetrate through the timing layer. Materials suitable for neutralizing layers and timing layers are disclosed in Research Disclosure July 1974, item 12331 and July 1975, item 13525.

In the image-receiving layer (1) and/or in said top layer (2) and/or in an alkali-neutralizing undercoat gelatin is used preferably as hydrophilic colloid. In layer (1) gelatin is present preferably for at least 60 % by weight and is optionally used in conjunction with an other hydrophilic colloid, e.g. polyvinyl alcohol, cellulose derivatives, preferably carboxymethyl cellulose, dextran, galactomannans, alginic acid derivatives, e.g. alginic acid sodium salt and/or watersoluble polyacrylamides. Said other hydrophilic colloid may be used also in the top layer for at most 10 % by weight and in the undercoat in an amount lower than the gelatin content.

The image-receiving layer and/or a hydrophilic colloid layer in water-permeable relationship therewith may comprise a silver halide developing agent and/or silver halide solvent, e.g. sodium thiosulphate in an amount of approximately 0.1 g to approximately 4 g per m².

The image-receiving layer or a hydrophilic colloid layer in water-permeable relationship therewith may comprise colloidal silica.

The image-receiving layer may contain as physical development accelerators, in operative contact with the developing nuclei, thioether compounds such as those described e.g. in DE-A-1,124,354; US-P 4,013,471; US-P 4,072,528 and in EP 26520.

According to a preferred embodiment the processing liquid and/or the DTR image-receiving material contains at least one image toning agent. In said case the image toning agent(s) may gradually transfer by diffusion from said image-receiving material into the processing liquid and keep therein the concentration of said agents almost steady. In practice such can be realized by using the silver image toning agents in a coverage in the range from 1 mg/m² to 20 mg/m² in a hydrophilic waterpermeable colloid layer.

A survey of suitable toning agents is given in the above mentioned book of André Rott and Edith Weyde, p. 61-65, preference being given to 1-phenyl-1H-tetrazole-5-thiol, also called 1-phenyl-5-mercapto-tetrazole, tautomeric structures and derivatives thereof such as 1-(2,3-dimethylphenyl)-5-mercaptotetrazole, 1-(3,4-dimethylcyclohexyl)-5-mercapto-tetrazole, 1-(4-methylphenyl)-5-mercapto-tetrazole, 1-(3-chloro-4-methylphenyl)-5-mercapto-tetrazole, 1-(3,4-dichlorophenyl)-5-mercapto-tetrazole. Further particularly useful toning agents are of the class of thiohydantoins and of the class of phenyl substituted mercapto-triazoles. Still further toning agents suitable for use in accordance with the preferred embodiment of the present invention are the toning agents described in published European patent applications

218752, 208346, 218753 and US-P 4,683,189.

In the security documents according to the present invention the transparent or translucent support is e.g. a clear resin film support or such support containing small amounts of pigments or voids opacifying to some degree the support. For example, white TiO₂ particles as described e.g. in published European patent application (EP-A) 0 324 192 are incorporated therein.

Organic resins suited for manufacturing transparent film supports are e.g. polycarbonates, polyesters, preferably polyethylene terephthalate, polystyrene and homo- and copolymers of vinyl chloride. Further are mentioned cellulose esters e.g. cellulose triacetate.

The above mentioned DTR image-receiving materials may be used in conjunction with any type of photosensitive material containing a silver halide emulsion layer. For continuous tone reproduction the silver halide comprises preferably a mixture of silver chloride, and silver iodide and/or silver bromide, at least 90 mole % based on the total mole of the silver halide being silver chloride, and the ratio by weight of hydrophilic colloid to silver halide expressed as silver nitrate is between 3:1 and 10:1.

The binder for the silver halide emulsion layer and other optional layers contained on the imaging element is preferably gelatin. But instead of or together with gelatin, use can be made of one or more other natural and/or synthetic hydrophilic colloids, e.g. albumin, casein, zein, polyvinyl alcohol, alginic acids or salts thereof, cellulose derivatives such as carboxymethyl cellulose, modified gelatin, e.g. phthaloyl gelatin etc. The weight ratio in the silver halide emulsion layer of hydrophilic colloid binder to silver halide expressed as equivalent amount of silver nitrate to binder is e.g. in the range of 1:1 to 10:1, but preferably for continuous tone reproduction is between 3.5:1 and 6.7:1.

The silver halide emulsions may be coarse or fine grain and can be prepared by any of the well known procedures e.g. single jet emulsions, double jet emulsions such as Lippmann emulsions, ammoniacal emulsions, thiocyanate- or thioether-ripened emulsions such as those described in US-P 2,222,264, 3,320,069, and 3,271,157. Surface image emulsions may be used or internal image emulsions may be used such as those described in US-P 2,592,250, 3,206,313, and 3,447,927. If desired, mixtures of surface and internal image emulsions may be used as described in US-P 2,996,382.

The silver halide particles of the photographic emulsions may have a regular crystalline form such as cubic or octahedral form or they may have a transition form. Regular-grain emulsions are described e.g. in J. Photogr. Sci., Vol. 12, No. 5, Sept./Oct. 1964, pp. 242-251. The silver halide grains may also have an almost spherical form or they may have a tabular form (so-called T-grains), or may have composite crystal forms comprising a mixture of regular and irregular crystalline forms. The silver halide grains may have a multilayered structure having a core and shell of different halide composition. Besides having a differently composed core and shell the silver halide grains may comprise also different halide compositions and metal dopants inbetween.

The average size expressed as the average diameter of the silver halide grains may range from 0.2 to 1.2 μm , preferably between 0.2 μm and 0.8 μm , and most preferably between 0.3 μm and 0.6 μm . The size distribution can be homodisperse or heterodisperse. A homodisperse size distribution is obtained when 95 % of the grains have a size that does not deviate more than 30 % from the average grain size.

The emulsions can be chemically sensitized e.g. by adding sulphur-containing compounds during the chemical ripening stage e.g. allyl isothiocyanate, allyl thiourea, and sodium thiosulphate. Also reducing agents e.g. the tin compounds described in BE-A 493,464 and 568,687, and polyamines such as diethylene triamine or derivatives of aminomethane-sulphonic acid can be used as chemical sensitizers. Other suitable chemical sensitizers are noble metals and noble metal compounds such as gold, platinum, palladium, iridium, ruthenium and rhodium. This method of chemical sensitization has been described in the article of R.KOSLOWSKY, Z. Wiss. Photogr. Photophys. Photochem. 46, 65-72 (1951).

The emulsions can also be sensitized with polyalkylene oxide derivatives, e.g. with polyethylene oxide having a molecular weight of 1000 to 20,000, or with condensation products of alkylene oxides and aliphatic alcohols, glycols, cyclic dehydration products of hexitols, alkyl-substituted phenols, aliphatic carboxylic acids, aliphatic amines, aliphatic diamines and amides. The condensation products have a molecular weight of at least 700, preferably of more than 1000. It is also possible to combine these sensitizers with each other as described in BE-P 537,278 and GB-P 727,982.

The silver halide emulsion may be sensitized panchromatically to ensure reproduction of all colors of the visible part of the spectrum or it may be orthochromatically sensitized.

The spectral photosensitivity of the silver halide can be adjusted by proper spectral sensitization by means of the usual mono- or polymethine dyes such as acidic or basic cyanines, hemicyanines, oxonols, hemioxonols, styryl dyes or others, also tri- or polynuclear methine dyes e.g. rhodacyanines or neocyanines. Such spectral sensitizers have been described by e.g. F.M. HAMER in "The Cyanine Dyes and Related Compounds" (1964) Interscience Publishers, John Wiley & Sons, New York.

The silver halide emulsions may contain the usual stabilizers e.g. homopolar or salt-like compounds of mercury with aromatic or heterocyclic rings such as mercaptotriazoles, simple mercury salts, sulphonium mercury double salts and other mercury compounds. Other suitable stabilizers are azaindenes, preferably tetra- or penta-azaindenes, especially those substituted with hydroxy or amino groups. Compounds of this kind have been described by BIRR in Z. Wiss. Photogr. Photophys. Photochem. 47, 2-27 (1952). Other suitable stabilizers are i.a. heterocyclic mercapto compounds e.g. phenylmercaptotetrazole, quaternary benzothiazole derivatives, and benzotriazole.

A survey of photographic silver halide emulsions and their preparation is given in Research Disclosure December 1989, item 308119.

Processing of the image-wise exposed photographic silver halide emulsion layer proceeds whilst in contact with an image receiving material according to the invention and is accomplished using an alkaline processing liquid having a pH preferably between 9 and 13. The pH of the alkaline processing liquid may be established using various alkaline substances. Suitable alkaline substances are inorganic alkali e.g. sodium hydroxide, potassium carbonate or alkanolamines or mixtures thereof. Preferably used alkanolamines are tertiary alkanolamines e.g. those described in EP-A-397925, EP-A-397926, EP-A-397927, EP-A-398435 and US-P 4,632,896. A combination of alkanolamines having both a pK_a above or below 9 or a combination of alkanolamines whereof at least one has a pK_a above 9 and another having a pK_a of 9 or less may also be used as disclosed in the Japanese patent applications laid open to the public numbers 73949/61, 73953/61, 169841/61, 212670/60, 73950/61, 73952/61, 102644/61, 226647/63, 229453/63, US-P-4,362,811, US-P 4,568,634 etc.. The concentration of these alkanolamines is preferably from 0.1 mol/l to 0.9 mol/l.

Suitable developing agents for the exposed silver halide are e.g. hydroquinone-type and 1-phenyl-3-pyrazolidone-type developing agents as well as p-monomethylaminophenol and derivatives thereof. Preferably used is a combination of a hydroquinone-type and 1-phenyl-3-pyrazolidone-type developing agent wherein the latter is preferably incorporated in one of the layers comprised on the support of the photographic material. A preferred class of 1-phenyl-3-pyrazolidone-type developing agents is disclosed in the published EP-A 449340.

According to a preferred embodiment for continuous tone reproduction a mixture of developing agents comprising an o-dihydroxybenzene, e.g. catechol, a 3-pyrazolidinone e.g. a 1-aryl-3-pyrazolidinone and optionally a p-dihydroxybenzene, e.g. hydroquinone the molar amount of the o-dihydroxybenzene in said mixture being larger than the molar amount of the 3-pyrazolidinone, and the p-dihydroxybenzene if any being present in a molar ratio of at most 5 % with respect to the o-dihydroxybenzene can be used. Other type of developing agents suitable for use in accordance with the present invention are reductiones e.g. ascorbic acid derivatives.

The developing agent or a mixture of developing agents can be present in an alkaline processing solution, in the photographic material or the image receiving material. In case the developing agent or a mixture of developing agents is contained in the photographic material and/or image receiving material, the processing solution can be merely an aqueous alkaline solution that initiates and activates the development.

5 In the DTR process the photographic element is developed in the presence of a silver halide solvent. Preferably used silver halide solvents are water soluble thiosulphate compounds such as ammonium and sodium thiosulphate, or ammonium and alkali metal thiocyanates. Other useful silver halide solvents (or "complexing agents") are described in the book "The Theory of the Photographic Process" edited by T.H. James, 4th edition, p. 474-475 (1977), in particular sulphites and uracil. Further interesting silver halide complexing agents are cyclic imides, preferably combined with alkanolamines, as described in US-P 4,297,430 and US-P 4,355,090. 2-mercaptobenzoic acid derivatives are described as silver halide solvents in US-P 4,297,429, preferably combined with alkanolamines or with cyclic imides and alkanolamines. Dialkylmethylenedisulfones can also be used as silver halide solvent.

10 The silver halide solvent is preferably present in the processing solution but may also be present in one or more layers comprised on the support of the imaging element and/or receiving material. When the silver halide solvent is incorporated in the photographic material it may be incorporated as a silver halide solvent precursor as disclosed in e.g. Japanese published unexamined patent applications no. 15247/59 and 271345/63, US-P 4,693,955 and US-P 3,685,991.

15 The processing solution for use in the production of black-and-white photographs in security documents according to the present invention may comprise other additives such as e.g. thickeners, preservatives, detergents e.g. acetylenic detergents such as SURFYNOL 104, SURFYNOL 465, SURFYNOL 440 etc. all available from Air Reduction Chemical Company, New York.

The DTR-process is normally carried out at a temperature in the range of 10°C to 35°C.

Further details about the black-and-white DTR process and also about the dye diffusion transfer process and image receiving materials used therein are described in Research Disclosure November 1976, item 15162.

25 The present invention will now be illustrated by the following examples without however limiting it thereto. All ratios, percentages and parts are by weight unless otherwise specified.

EXAMPLE 1

30 - Preparation of photographic element for use in the DTR process

A gelatine silver halide emulsion was prepared by slowly running with stirring an aqueous solution of 1 mole of silver nitrate per liter into a gelatine solution containing per mole of silver nitrate 41 g of gelatin, 1.2 mole of sodium chloride, 0.08 mole of potassium bromide and 0.01 mole of potassium iodide.

35 The temperature during precipitation and the subsequent ripening process lasting three hours was kept at 40°C.

Before cooling, shredding and washing 214 g of gelatin were added per mole of silver halide. The washed noodles were molten and another 476 g of gelatin were added per mole of silver halide during the chemical ripening. After ripening 285 g of gelatin in the form of a 20 % aqueous solution were added to the emulsion per mole of silver halide as well as hydroquinone in an amount such that after coating 0.9 g of hydroquinone were present per m² and 1-phenyl-4,4-dimethyl-3-pyrazolidinone in an amount such that 0.21 g thereof were present per m². The emulsion was coated at one side of a subbed water-resistant paper support consisting of a paper having a weight of 130 g/m² coated at both sides with a polyethylene stratum at a ratio of 20 g/m² per side.

40 The emulsion was coated in such a way that an amount of silver equivalent to 1.5 g of silver nitrate was applied per m². The amount of gelatin corresponding therewith is 8.93 g/m² since the gelatin to silver nitrate weight ratio was 5.97.

45 - Preparation of image receiving material for use in the DTR process and containing light interference pigments

50 One side of a double-side subbed transparent polyethylene terephthalate support having a thickness of 0.1 mm was coated after corona treatment at a dry coverage of 2.5 g/m² of gelatin and 1.3 g/m² of interference pigment from the following coating composition:

carboxymethyl cellulose	12 g
gelatin	38.5 g
3 % aqueous dispersion of colloidal Ag ₂ S.NiS nuclei	14 ml
4 % aqueous solution of formaldehyde	12 ml
aqueous dispersion of blue PALIOSECURE type EC 1408 (tradename) containing 30 % of said blue pigment and 8 % of gelatin	80 g
12.5 % solution of saponine in ethanol/water (20/80)	20 ml

The other side of said support was coated with the above mentioned image-receiving layer coating composition, with the difference however, that the blue interference pigment PALIOSECURE type EC 1408 (tradename) pigment was replaced by yellow interference pigment IRIODINE 9231 (tradename).

- Printing of the image receiving material with pattern of graphical and numerical information using a blue non-iridescent ink

The printing of said information was carried out in the background area having a yellow color (on observation in reflection mode) due to the presence of said interference pigment IRIODINE 9231 (tradename).

DTR-image formation

The above defined photographic element was image-wise exposed in a reflex camera to obtain therein a photograph (portrait) of the passport owner.

The photo-exposed element was pre-moistened with a processing liquid as defined hereinafter.

The contact time of the photo-exposed element with said liquid was 6 seconds before being pressed together with the image-receiving material at the blue-pigment side as defined above. The transfer processor employed was a COPYPROOF (registered trade name of AGFA-GEVAERT N.V.) type CP 380. The transfer contact time was 30 seconds. In the image-receiving layer a positive black-and-white (silver image) portrait of the photographed person was obtained.

- Composition of the processing liquid:

hydroxyethyl cellulose	1.0 g
Ethylenediaminetetraacetic acid tetrasodium salt	2.0 g
Na ₂ SO ₃	45.0 g
Na ₂ S ₂ O ₃	14.0 g
KBr	0.5 g
1-Phenyl-5-mercapto-tetrazole	0.1 g
1-(3,4-Dichlorophenyl)-1H-tetrazole-5-thiol	0.02 g
N-methyl-ethanolamine	45.0 ml
N-methyl-diethanolamine	30.0 ml
Water up to	1 l

When viewed in daylight under an angle of 90° in reflection mode the color of the non-printed area around the portrait (inspection at the front side) was blue due the presence of uniformly distributed therein PALIOSECURE type EC 1408 - BLUE (tradename). In the transmission mode the color in that background area became slightly brownish yellow

at the front side and blue at the rear side.

On copying the obtained document with a color copier (CANON CLC 500) the parts of the document around the portrait were reproduced grey (yellow plus blue) having the blue printed graphical information of non-iridescent pigment with poor contrast thereon.

5

EXAMPLE 2

- Preparation of image-receiving element for use in dye diffusion transfer process

10

A transparent polyvinyl chloride sheet having a thickness of 0.100 mm was after corona treatment coated at one side with the following compositions for forming a subbing layer and mordanting layer respectively :

1. Subbing layer coating composition

15

gelatin	4 g
aqueous dispersion of blue PALIOSECURE type EC 1408 (tradename) containing 30 % of said blue pigment and 8 % of gelatin	200 g
ingredient A 40 % solution dispersed in aqueous medium	250 ml
5 % solution of siloxane compound in ethanol	125 ml
12.5 % solution of saponine in ethanol/water 20/80	20 ml

30

Ingredient A is a polyester-polyurethane having the same chemical composition as described in US-P 4,902,593, column 2, lines 64-68 and column 3, lines 1-8.

The coating composition was applied coated at a dry coverage of 0.4 g/m² of gelatin and 1.2 g of interference pigment.

2. Coating composition of the mordanting layer

35

gelatin	20 g
mordant M (20 % solution)	250 ml
saponine (12 %) and wetting agent W (5 %) in water	32 ml
aqueous 4 % solution of formaldehyde	10 ml

45

Mordant M on the basis of an epoxidized cationic polymer has the same composition as described in US-P 4,902,593, column 7, lines 14-42.

The coating composition was applied at a dry coverage of 0.9 g/m² of gelatin.

50

The other side of said support was coated with the above mentioned image-receiving layer coating composition, with the difference however, that the blue interference pigment PALIOSECURE type EC 1408 (tradename) pigment was replaced by yellow interference pigment IRIODINE 9231 (tradename).

55

The above defined image-receiving material was processed in combination with a photographic dye diffusion transfer material as described in the Example of U.S. Pat. No. 4,496,645, which material was exposed to reproduce thereon a portrait. The exposed material was kept for 1 minute in contact with the above defined image-receiving material after being led through a diffusion transfer apparatus COPYPROOF CP 38 (tradename of Agfa-Gevaert N.V. Belgium) having in its tray the following basic processing liquid :

sodium hydroxide	25 g
sodium orthophosphate	25 g
cyclohexane dimethanol	25 g
2,2' methypropylpropane diol	25 g
N-ethylbenzene-pyridinium chloride	0.5 g
distilled water up to	1000 ml

After leaving the processing tray the image-receiving sheet was led through a second tray containing an aqueous solution of the already mentioned wetting agent W corresponding with the following formula : iso-nonyl-phenoxy-(CH₂-O)₉-H and potassium iodide (ref. EP 0250657).

After drying the processed sheet material it was laminated as described in US-P 4,902,593 to obtain a sealed I.D. card.

EXAMPLE 3

The interference pigments mentioned in Example 2 were applied uniformly in front and rear mordanting layers respectively instead of in the subbing layers of an image-receiving material suited for use in a dye diffusion transfer process.

- Preparation of the image-receiving element

A transparent polyvinyl chloride sheet having a thickness of 0.100 mm was after corona treatment coated at one side with the following compositions for forming a subbing layer and mordanting layer respectively :

1. Coating composition of the subbing layer

gelatin	20 g
ingredient A 40 % solution dispersed in aqueous medium	250 ml
5 % solution of siloxane compound in ethanol	125 ml
12.5 % solution of saponine in ethanol/water 20/80	20 ml

The coating composition was applied coated at a dry coverage of 0.4 g/m² of gelatin.

2. Coating composition of the front mordanting layer

gelatin	12 g
aqueous dispersion of blue PALIOSECURE type EC 1408 (tradename) containing 30 % of said blue pigment and 8 % of gelatin	100 g
mordant M (20 % solution)	250 ml
saponine (12 %) and wetting agent W (5 %) in water	32 ml
aqueous 4 % solution of formaldehyde	10 ml

3. Coating composition of the rear mordanting layer

5

gelatin	12 g
aqueous dispersion of yellow IRIODINE 9231 (tradename) containing 30 % of yellow pigment and 8 % of gelatin	100 g
mordant M (20 % solution)	250 ml
saponine (12 %) and wetting agent W (5 %) in water	32 ml
aqueous 4 % solution of formaldehyde	10 ml

15

The coating composition was applied at a dry coverage of 0.9 g/m² of gelatin, and 1.3 g/m² of interference pigment.

20

EXAMPLE 4

Example 3 was repeated with the difference that the light interference pigments were applied uniformly in a gelatin top coat covering the mordanting layer. The dried top coat contained 0.5 g/m² of gelatin and 1.3 g/m² of interference pigment at each side of the transparent support.

25

Claims

1. A security document which contains at least one layer and a transparent or translucent support and at least one image or pattern serving for identification purposes, characterized in that said document contains at least one light interference pigment distributed uniformly or patternwise in or on at least one layer of said document.
2. Document according to claim 1, wherein said document contains mixtures of different light interference pigments.
3. Document according to claim 1 or 2, wherein in said document different light interference pigments are present uniformly each in a different layer at opposite sides of said support.
4. Document according to claim 1 or 2, wherein in said document different interference pigments are present uniformly each in a different layer at opposite sides of said support and at least one of said layers has underneath and/or on top a pattern containing common light-reflecting pigments and/or dyes having no light interference properties.
5. Document according to claim 4, wherein said pattern has substantially the same color as the color seen in transmission mode or reflection mode of the light interference pigments combined with said pattern.
6. Document according to claim 1 or 2, wherein pattern-wise printed interference pigments are present underneath and/or on top of a pattern containing common light-reflecting pigments and/or dyes having no light interference properties.
7. Document according to claim 1 or 2, wherein a pattern of printed interference pigments is present underneath and/or on top of a layer or support having a color substantially the same as the color of said pattern containing said interference pigments when seen in reflection or transmission mode.
8. Document according to claim 1 or 2, wherein printed information containing light interference pigments A having underneath printed information containing normal light-absorbing and light-reflecting pigments R are present at one side of a transparent support TS and at the other side of said support said normal pigments R are printed in a pattern being overprinted at least partly by a pattern containing light interference pigments B.
9. Document according to claim 1 or 2, wherein information containing light interference pigments A at one side of a

65

- transparent support TS is patternwise printed over (1) a "common" light reflecting pigment pattern R1 of which the color is complementary to the color of said pigments A when seen with reflected light, (2) a pigment pattern comprising "common" light reflecting pigments R1 mixed with colored fluorescent or phosphorescent pigments or dyes RF, and at the other side of said support TS interference pigments B are printed over (1) a metallic pigment (aluminum or bronze platelets) pattern M, (2) a pattern comprising light reflecting pigments R2 having a color complementary to the color of said pigments B when seen with reflected light, (3) a pattern comprising metallic pigments M mixed with "common" light reflecting pigments R2 having a color complementary to the color of said pigments B when seen with reflected light.
- 5
- 10 10. Document according to any of the preceding claims, wherein said document contains a photographically obtained image or pattern.
11. Document according to claim 10, wherein said photographically obtained image or pattern is produced by means of developed photosensitive silver halide directly in a light-sensitive material itself or in a non-light-sensitive image receiving material.
- 15
12. Document according claim 10, wherein said photographically obtained image or pattern is produced by means of a non-impact printing technique in which analog or digital input signals for controlling said printing stem from photo-signals originating from a visible original.
- 20
13. Document according to claim 10, wherein said photographically produced image or pattern is formed by the silver salt diffusion transfer process in an image-receiving material containing an image receiving layer comprising development nuclei.
- 25
14. Document according to claim 10, wherein said photographically produced image or pattern is formed by a dye diffusion transfer process in an image-receiving material containing a mordant for a dye transferred from an image-wise exposed and developed silver halide emulsion material.
15. Document according according to any of the preceding claims, wherein said interference pigments are mica platelets coated with a metal oxide.
- 30
16. Document according to claim 15, wherein said metal oxide is selected from the group consisting of TiO_2 , ZrO_2 , Fe_2O_3 and Cr_2O_3 .
- 35
17. Document according to claim 15 or 16, wherein said platelets coated with said metal oxide have a second coating of carbon.
18. Document according to any of claims 15 to 17, wherein said platelets have a largest surface diameter between 5 and 200 μm .
- 40
19. Document according to any of claims 15 to 18, wherein the thickness of said interference pigments is between 0.1 and 0.6 μm .
- 45
20. Document according to any of the preceding claims, wherein said light interference pigments are present in said document in a coverage of 0.3 g/m^2 to 10 g/m^2 .
21. Document according to any of the preceding claims, wherein said support has been coated directly by sputtering with a thin metal oxide layer or has been coated with said metal oxide layer on top of a coating or pattern of said light interference pigments and/or coating or pattern of light reflecting pigments having no light interference properties taking care that the thus coated metal oxide layer has substantially the same or color complementary to the color of said patternwise applied pigments.
- 50
22. Document according to any of the preceding claims, wherein on the front and/or rear side of said support underneath and/or on top of uniformly or patternwise applied interference pigments a printed guilloche line pattern with rainbow effect is present, containing therefor light reflecting pigments showing that effect so as to have one or more of the rainbow colors the same as the normal or complementary color of said light interference pigments.
- 55
23. Document according to claim 22, wherein one or more of the rainbow colors is obtained by printing metallic pigments.

24. Document according to claim 22, wherein fluorescent or phosphorescent pigments have been mixed with said light interference pigments and/or with said light reflecting pigments giving said rainbow effect to the guilloche pattern.
25. Document according to claim 22, wherein said rainbow effect is obtained by printing a transparent varnish loaded with a fluorescent or phosphorescent pigment.
26. Document according to claim 22, wherein (a) bi-fluorescent pigment(s) is (are) mixed with one of said light reflecting pigments and/or mixed with said light interference pigments whereby when exposed to ultraviolet light said fluorescent pigment(s) show(s) light of two different wavelength ranges one of which is different from the wavelength range of the colors of said light reflecting and interference pigments when these are observed under visible light conditions and the other corresponds with the normal or complementary color of said interference pigments.
27. Document according to any of the preceding claims, wherein a guilloche pattern with rainbow effect is printed in perfect see-through print register on the front and rear side of said support, and wherein the light reflecting pigments showing rainbow effect printed at one side have complementary color with respect to the pigments printed, but have at one side a color the same as the normal color of said light interference pigments, and wherein parts of said guilloche pattern at either side cover at least partly a photograph or printed pattern or complete a printed pattern.
28. Document according to any of the preceding claims, wherein said document contains printed patterns at least partly covering each other and said patterns each contain (a) different light interference pigment(s) the construction and composition of which is such that they show a different color shift when viewed under the same observation angle, and wherein the printed pattern most remote from the observer has higher covering power than the pattern printed thereon which is more transparent, hereby obtaining a document that shows in the overlapping pattern area a continuously changing color shift by changing gradually the observation angle.
29. Document according to any of the preceding claims, wherein said light interference pigments are contained in said support.
30. Document according to any of the preceding claims, wherein said document is in the form of a laminate.

Patentansprüche

1. Ein Sicherheitsdokument, das wenigstens eine Schicht und einen durchsichtigen oder durchscheinenden Träger und wenigstens ein zu Identifikationszwecken dienendes Bild oder Muster enthält, dadurch gekennzeichnet, daß das Dokument wenigstens ein gleichmäßig oder mustermäßig in oder auf wenigstens einer Schicht dieses Dokuments verteiltes Lichtinterferenzpigment enthält.
2. Dokument nach Anspruch 1, dadurch gekennzeichnet, daß das Dokument Mischungen aus verschiedenen Lichtinterferenzpigmenten enthält.
3. Dokument nach Anspruch 1 oder 2, dadurch gekennzeichnet, daß in diesem Dokument verschiedene Lichtinterferenzpigmente je gleichmäßig in einer unterschiedlichen, an den gegenüberliegenden Seiten des Trägers befindlichen Schicht enthalten sind.
4. Dokument nach Anspruch 1 oder 2, dadurch gekennzeichnet, daß in diesem Dokument verschiedene Lichtinterferenzpigmente je gleichmäßig in einer unterschiedlichen, an den gegenüberliegenden Seiten des Trägers befindlichen Schicht enthalten sind und wenigstens eine dieser Schichten auf deren Unterseite und/oder Oberseite ein Muster mit üblichen lichtreflektierenden Pigmenten und/oder Farbstoffen ohne Lichtinterferenzeigenschaften enthält.
5. Dokument nach Anspruch 4, dadurch gekennzeichnet, daß das Muster wesentlich dieselbe Farbe hat wie die Farbe, die bei der Durchsicht- oder Aufsichtbetrachtung der Lichtinterferenzpigmente in Kombination mit diesem Muster beobachtet wird.
6. Dokument nach Anspruch 1 oder 2, dadurch gekennzeichnet, daß unter und/oder auf einem Muster mit üblichen lichtreflektierenden Pigmenten und/oder Farbstoffen ohne Lichtinterferenzeigenschaften mustermäßig gedruckte Interferenzpigmente enthalten sind.

7. Dokument nach Anspruch 1 oder 2, dadurch gekennzeichnet, daß unter und/oder auf einer Schicht oder einem Träger ein Muster von gedruckten Interferenzpigmenten enthalten ist, wobei die Schicht bzw. der Träger bei Durchsicht- oder Aufsichtbetrachtung wesentlich dieselbe Farbe wie die Farbe des die Interferenzpigmente enthaltenden Musters aufweist.
- 5
8. Dokument nach Anspruch 1 oder 2, dadurch gekennzeichnet, daß gedruckte Information enthaltende Lichtinterferenzpigmente A, unter denen sich gedruckte Information enthaltende, normale, lichtabsorbierende und lichtreflektierende Pigmente R befinden, auf einer Seite eines durchsichtigen Trägers TS enthalten sind und auf der anderen Seite des Trägers die normalen Pigmente R in einem wenigstens teilweise durch ein Lichtinterferenzpigmente B enthaltendes Muster überdruckten Muster gedruckt werden.
- 10
9. Dokument nach Anspruch 1 oder 2, dadurch gekennzeichnet, daß Information enthaltende Lichtinterferenzpigmente A auf einer Seite eines durchsichtigen Trägers TS mustermäßig über (1) einem "übliche" lichtreflektierende Pigmente R1 enthaltenden Muster, deren Farbe bei Aufsichtbetrachtung mit der Farbe der Pigmente A komplementär ist, und (2) einem Pigmentmuster mit "üblichen" lichtreflektierenden, mit gefärbten fluoreszierenden oder phosphoreszierenden Pigmenten oder Farbstoffen RF, vermischten Pigmenten R1 gedruckt werden und auf der anderen Seite des Trägers TS Interferenzpigmente B über (1) einem Metallpigmente (Aluminium- oder Bronzeplatten) enthaltenden Muster M, (2) einem Muster mit lichtreflektierenden Pigmenten R2, die bei Aufsichtbetrachtung eine mit der Farbe der Pigmente B komplementäre Farbe aufweisen, und (3) einem Muster mit Metallpigmenten M, die mit "normalen" lichtreflektierenden Pigmenten R2, die bei Aufsichtbetrachtung eine mit der Farbe der Pigmente B komplementäre Farbe aufweisen, vermischt sind, gedruckt werden.
- 15
- 20
10. Dokument nach irgendeinem der vorstehenden Ansprüche, dadurch gekennzeichnet, daß das Dokument ein fotografisch erhaltenes Bild oder Muster enthält.
- 25
11. Dokument nach Anspruch 10, dadurch gekennzeichnet, daß das fotografisch erhaltene Bild oder Muster unter Anwendung von entwickeltem fotoempfindlichem Silberhalogenid direkt in einem lichtempfindlichen Material selber oder in einem lichtunempfindlichen Bildempfangsmaterial erzeugt wird.
- 30
12. Dokument nach Anspruch 10, dadurch gekennzeichnet, daß das fotografisch erhaltene Bild oder Muster durch eine anschlagnfreie Drucktechnik, bei der analoge oder digitale, den Druckvorgang steuernde Eingangssignale von durch eine sichtbare Vorlage emittierten Fotosignalen stammen, erzeugt wird.
- 35
13. Dokument nach Anspruch 10, dadurch gekennzeichnet, daß das fotografisch erzeugte Bild oder Muster gemäß dem Silbersalzdifusionsübertragungsverfahren in einem Bildempfangsmaterial mit einer Entwicklungskeime enthaltenden Bildempfangsschicht erzeugt wird.
- 40
14. Dokument nach Anspruch 10, dadurch gekennzeichnet, daß das fotografisch erzeugte Bild oder Muster entsprechend einem Farbstoffdifusionsübertragungsverfahren in einem Bildempfangsmaterial, das ein Beizmittel für einen von einem bildmäßig belichteten und entwickelten Silberhalogenidemulsionsmaterial übertragenen Farbstoff enthält, erhalten wird.
- 45
15. Dokument nach irgendeinem der vorstehenden Ansprüche, dadurch gekennzeichnet, daß die Interferenzpigmente mit einem Metalloxid überzogene Mikoplatten sind.
- 50
16. Dokument nach Anspruch 15, dadurch gekennzeichnet, daß das Metalloxid TiO_2 , ZrO_2 , Fe_2O_3 oder Cr_2O_3 ist.
- 55
17. Dokument nach Anspruch 15 oder 16, dadurch gekennzeichnet, daß die mit dem Metalloxid überzogenen Platten eine zweite, aus Kohlenstoff bestehende Schicht haben.
18. Dokument nach irgendeinem der Ansprüche 15 bis 17, dadurch gekennzeichnet, daß der Höchstoberflächendurchmesser der Platten zwischen 5 und 200 μm liegt.
- 65
19. Dokument nach irgendeinem der Ansprüche 15 bis 18, dadurch gekennzeichnet, daß die Stärke der Interferenzpigmente zwischen 0,1 und 0,6 μm liegt.
20. Dokument nach irgendeinem der vorstehenden Ansprüche, dadurch gekennzeichnet, daß die Lichtinterferenzpigmente in einem Verhältnis zwischen 0,3 g/m^2 und 10 g/m^2 im Dokument enthalten sind.

21. Dokument nach irgendeinem der vorstehenden Ansprüche, dadurch gekennzeichnet, daß der Träger entweder direkt durch Aufstäuben mit einer dünnen Metalloxydschicht oder oben auf einer Schicht oder einem Muster mit den Lichtinterferenzpigmenten und/oder oben auf einer Schicht oder einem Muster mit lichtreflektierenden Pigmenten ohne Lichtinterferenzeigenschaften mit der Metalloxydschicht überzogen ist, wobei darauf geachtet wird, daß die so aufgetragene Metalloxydschicht wesentlich dieselbe Farbe wie die Farbe der mustermäßig angebrachten Pigmente oder eine damit komplementäre Farbe aufweist.
22. Dokument nach irgendeinem der vorstehenden Ansprüche, dadurch gekennzeichnet, daß sich an der Vorderseite und/oder der Rückseite des Trägers unter und/oder auf gleichmäßig oder mustermäßig aufgetragenen Interferenzpigmenten ein gedrucktes Guillochemuster mit Regenbogeneffekt befindet, wobei dieses Muster zum Erhalt dieses Effekts lichtreflektierende, den Regenbogeneffekt aufweisende Pigmente enthält, so daß eine oder mehr Regenbogenfarben dieselbe Farbe ist bzw. sind wie die normale oder komplementäre Farbe der Lichtinterferenzpigmente.
23. Dokument nach Anspruch 22, dadurch gekennzeichnet, daß eine oder mehr Regenbogenfarben durch Aufdrucken von Metallpigmenten erhalten werden.
24. Dokument nach Anspruch 22, dadurch gekennzeichnet, daß fluoreszierende oder phosphoreszierende Pigmente mit den Lichtinterferenzpigmenten und/oder den lichtreflektierenden Pigmenten vermischt sind und dem Guillochemuster dadurch den Regenbogeneffekt verleihen.
25. Dokument nach Anspruch 22, dadurch gekennzeichnet, daß der Regenbogeneffekt durch Aufdrucken eines durchsichtigen, mit einem fluoreszierenden oder phosphoreszierenden Pigment geladenen Lacks erhalten wird.
26. Dokument nach Anspruch 22, dadurch gekennzeichnet, daß (ein) bifluoreszierende(s) Pigment(e) mit einem der lichtreflektierenden Pigmente und/oder mit den Lichtinterferenzpigmenten vermischt ist (sind), wobei das (die) Fluoreszenzpigment(e) bei Belichtung mit Ultraviolettlicht Licht von zwei unterschiedlichen Wellenbereichen aufweist (aufweisen), von denen sich einer bei Betrachtung unter sichtbarem Licht der lichtreflektierenden Pigmente und Lichtinterferenzpigmente vom Wellenbereich der Farben der lichtreflektierenden Pigmente und Lichtinterferenzpigmente unterscheidet und der andere der normalen oder komplementären Farbe der Interferenzpigmente entspricht.
27. Dokument nach irgendeinem der vorstehenden Ansprüche, dadurch gekennzeichnet, daß ein Guillochemuster mit Regenbogeneffekt in perfektem Durchsichtdruckregister auf der Vorderseite und Rückseite des Trägers gedruckt wird, die an einer Seite gedruckten, lichtreflektierenden, den Regenbogeneffekt aufweisenden Pigmente eine mit der Farbe der gedruckten Pigmente komplementäre Farbe, aber auf einer Seite eine der normalen Farbe der Lichtinterferenzpigmente entsprechende Farbe aufweisen, und Teile des Guillochemusters an beiden Seiten wenigstens teilweise ein Lichtbild oder gedrucktes Muster bedecken oder ein gedrucktes Muster vervollständigen.
28. Dokument nach irgendeinem der vorstehenden Ansprüche, dadurch gekennzeichnet, daß das Dokument gedruckte Muster, die wenigstens teilweise einander bedecken, und jedes dieser Muster (ein) unterschiedliche(s) Lichtinterferenzpigment(e) enthält, das (die) so strukturiert und zusammengesetzt ist (sind), daß es (sie) bei Betrachtung unter demselben Beobachtungswinkel eine unterschiedliche Farbverschiebung aufweist (aufweisen), und daß das am weitesten vom Beobachter entfernt liegende gedruckte Muster ein höheres Deckvermögen aufweist als das darauf gedruckte, durchsichtigere Muster, wodurch ein Dokument, bei dem unter stufenweiser Änderung des Beobachtungswinkels im überlappenden Musterbereich eine sich ununterbrochen ändernde Farbverschiebung festgestellt wird, erhalten wird.
29. Dokument nach irgendeinem der vorstehenden Ansprüche, dadurch gekennzeichnet, daß die Lichtinterferenzpigmente im Träger enthalten sind.
30. Dokument nach irgendeinem der vorstehenden Ansprüche, dadurch gekennzeichnet, daß das Dokument in Form eines Laminats vorliegt.

55 Revendications

1. Un document de sécurité qui contient au moins une couche et un support transparent ou translucide et au moins une image ou motif servant à des fins d'identification, caractérisé en ce que ce document contient au moins un pigment d'interférence lumineuse distribué uniformément ou sous forme de motif dans ou sur au moins une couche

de ce document.

2. Document selon la revendication 1, caractérisé en ce qu'il contient des mélanges de différents pigments d'interférence lumineuse.
- 5 3. Document selon la revendication 1 ou 2, caractérisé en ce que dans ce document différents pigments d'interférence lumineuse sont chacun présents de manière uniforme dans une couche différente des côtés opposés du support.
- 10 4. Document selon la revendication 1 ou 2, caractérisé en ce que dans ce document différents pigments d'interférence sont chacun présents de manière uniforme dans une couche différente des côtés opposés du support et au moins une de ces couches a au-dessous et/ou au-dessus un motif contenant des pigments et/ou colorants ordinaires réfléchissant la lumière et exempts de propriétés d'interférence lumineuse.
- 15 5. Document selon la revendication 4, caractérisé en ce que ce motif a essentiellement la même couleur que la couleur vue en transmission ou en réflexion des pigments d'interférence lumineuse combinés avec ledit motif.
6. Document selon la revendication 1 ou 2, caractérisé en ce que les pigments d'interférence imprimés sous forme de motif sont présents au-dessous et/ou au-dessus d'un motif contenant des pigments et/ou colorants ordinaires réfléchissant la lumière et exempts de propriétés d'interférence lumineuse.
- 20 7. Document selon la revendication 1 ou 2, caractérisé en ce qu'un motif de pigments d'interférence imprimés est présent au-dessous et/ou au-dessus d'une couche ou d'un support possédant essentiellement la même couleur que la couleur dudit motif contenant les pigments d'interférence lorsqu'on l'observe en réflexion ou en transmission.
- 25 8. Document selon la revendication 1 ou 2, caractérisé en ce que de l'information imprimée contenant les pigments d'interférence lumineuse A au-dessous de laquelle est imprimée de l'information contenant des pigments ordinaires R absorbant et réfléchissant la lumière est présente sur un côté d'un support transparent TS et sur l'autre côté de ce support lesdits pigments ordinaires R sont imprimés dans un motif qui est surimprimé au moins partiellement
- 30 par un motif contenant des pigments d'interférence lumineuse B.
9. Document selon la revendication 1 ou 2, caractérisé en ce que de l'information contenant des pigments d'interférence lumineuse A sur un côté d'un support transparent TS est imprimée sous forme de motif au-dessus (1) d'un motif R1 de pigment "ordinaire" réfléchissant la lumière dont la couleur est complémentaire à la couleur desdits pigments A lorsqu'on les observe à la lumière réfléchie, (2) d'un motif de pigment comprenant des pigments "ordinaires" B1 réfléchissant la lumière et mélangés avec des colorants ou pigments RF colorés fluorescents ou phosphorescents, et sur l'autre côté dudit support TS des pigments d'interférence B sont imprimés au-dessus (1) d'un motif M de pigment métallique (paillettes d'aluminium ou de bronze), (2) d'un motif comprenant des pigments R2 réfléchissant la lumière avec une couleur complémentaire à la couleur desdits pigments B lorsqu'on les observe à la lumière réfléchie, (3) d'un motif comprenant des pigments métalliques M mélangés avec des pigments "ordinaires" R2 réfléchissant la lumière avec une couleur complémentaire à la couleur desdits pigments B lorsqu'on les observe à la lumière réfléchie.
- 35 40 10. Document selon l'une quelconque des revendications précédentes, caractérisé en ce qu'il contient une image ou un motif obtenu(e) par voie photographique.
- 45 11. Document selon la revendication 10, caractérisé en ce que cette image ou ce motif obtenu(e) par voie photographique est produit(e) au moyen d'un halogénure d'argent photosensible développé directement dans un matériau sensible à la lumière ou dans un matériau récepteur d'image non-sensible à la lumière.
- 50 12. Document selon la revendication 10, caractérisé en ce que cette image ou ce motif obtenu(e) par voie photographique est produit(e) au moyen d'une technique d'impression sans impact dans laquelle des signaux d'entrée digitaux ou analogues pour commander cette impression proviennent de photosignaux provenant d'un original visible.
- 55 13. Document selon la revendication 10, caractérisé en ce que cette image ou ce motif produit(e) par voie photographique est formé(e) par le procédé de transfert de sel d'argent par diffusion dans un matériau récepteur d'image contenant une couche réceptrice d'image comprenant des germes de développement.
14. Document selon la revendication 10, caractérisé en ce que cette image ou ce motif produit(e) par voie photogra-

phique est formé(e) par un procédé de transfert de colorant par diffusion dans un matériau récepteur d'image contenant un mordant pour un colorant transféré à partir d'un matériau d'émission à l'halogénure d'argent exposé et développé sous forme d'image.

- 5 15. Document selon l'une quelconque des revendications précédentes, caractérisé en ce que les pigments d'interférence sont des paillettes mica enduites d'un oxyde métallique.
16. Document selon la revendication 15, caractérisé en ce que l'oxyde métallique est choisi parmi TiO_2 , ZrO_2 , Fe_2O_3 et Cr_2O_3 .
- 10 17. Document selon la revendication 15 ou 16, caractérisé en ce que les paillettes enduites de l'oxyde métallique sont recouvertes d'une deuxième couche de carbone.
18. Document selon l'une quelconque des revendications 15 à 17, caractérisé en ce que les paillettes ont un diamètre de surface maximal entre 5 et 200 μm .
- 15 19. Document selon l'une quelconque des revendications 15 à 18, caractérisé en ce que l'épaisseur des pigments d'interférence se situe entre 0,1 et 0,6 μm .
- 20 20. Document selon l'une quelconque des revendications précédentes, caractérisé en ce que les pigments d'interférence lumineuse sont présents dans ce document à raison de 0,3 g/m^2 à 10 g/m^2 .
21. Document selon l'une quelconque des revendications précédentes, caractérisé en ce que le support a été enduit directement par pulvérisation cathodique d'une mince couche d'oxyde métallique ou a été enduit de cette couche d'oxyde métallique au-dessus d'un enduit ou motif desdits pigments d'interférence lumineuse et/ou d'un enduit ou motif de pigments réfléchissant la lumière ne possédant pas de propriétés d'interférence lumineuse, veillant à ce que la couche d'oxyde métallique ainsi appliquée ait essentiellement la même couleur ou une couleur complémentaire à celle des pigments appliqués sous forme de motif.
- 25 22. Document selon l'une quelconque des revendications précédentes, caractérisé en ce que sur le front et/ou le dos dudit support - au-dessous et/ou au-dessus des pigments d'interférence appliqués uniformément ou sous forme de motif - est présent un motif en lignes guillochées avec effet arc-en-ciel qui contient à cette fin des pigments réfléchissant la lumière procurant cet effet de sorte qu'une ou plusieurs des couleurs arc-en-ciel sont identiques à la couleur normale ou complémentaire des pigments d'interférence lumineuse.
- 30 23. Document selon la revendication 22, caractérisé en ce qu'un ou plusieurs des couleurs arc-en-ciel sont obtenus en imprimant des pigments métalliques.
24. Document selon la revendication 22, caractérisé en ce que des pigments fluorescents ou phosphorescents ont été mélangés avec lesdits pigments d'interférence lumineuse et/ou avec lesdits pigments réfléchissant la lumière procurant cet effet arc-en-ciel au motif guilloché.
- 40 25. Document selon la revendication 22, caractérisé en ce que l'effet arc-en-ciel est obtenu en imprimant un vernis transparent chargé d'un pigment fluorescent ou phosphorescent.
- 45 26. Document selon la revendication 22, caractérisé en ce qu'un ou plusieurs pigments bi-fluorescents sont mélangés avec un des pigments réfléchissant la lumière et/ou mélangés avec les pigments d'interférence lumineuse, ce(s) pigment(s) fluorescent(s) montrant - lorsqu'il(s) est (sont) exposé(s) à la lumière ultraviolette - de la lumière de deux domaines de longueur d'onde différents dont l'un est différent du domaine de longueur d'onde des couleurs desdits pigments d'interférence et réfléchissant la lumière lorsqu'on les observe sous des conditions de lumière visible et l'autre correspond à celui de la couleur normale ou complémentaire desdits pigments d'interférence.
- 50 27. Document selon l'une quelconque des revendications précédentes, caractérisé en ce qu'un motif guilloché avec effet arc-en-ciel est imprimé en parfait registre d'impression translucide sur le front et le dos dudit support, et caractérisé en ce que les pigments réfléchissant la lumière présentant l'effet arc-en-ciel et imprimés sur un côté possèdent une couleur complémentaire par rapport aux pigments imprimés, mais possèdent sur un côté une couleur identique à la couleur normale desdits pigments d'interférence lumineuse, et caractérisé en ce que des parties dudit motif guilloché sur chaque côté recouvrent au moins partiellement une photo ou un motif imprimé ou complètent un motif imprimé.
- 55

28. Document selon l'une quelconque des revendications précédentes, caractérisé en ce que ce document contient des motifs imprimés se chevauchant au moins partiellement et chaque motif contient un ou plusieurs pigments d'interférence lumineuse différents dont la construction et la composition sont telles que les pigments présentent un changement de couleur différent lorsqu'on les observe sous le même angle d'observation, et caractérisé en ce que le motif imprimé qui est le plus éloigné de l'observateur a un pouvoir couvrant plus élevé que le motif imprimé là-dessus qui est plus transparent, obtenant de cette manière un document qui présente dans la zone de chevauchement du motif un changement constant de la couleur en changeant graduellement l'angle d'observation.

29. Document selon l'une quelconque des revendications précédentes, caractérisé en ce que les pigments d'interférence lumineuse sont contenu dans ledit support.

30. Document selon l'une quelconque des revendications précédentes, caractérisé en ce qu'il est sous forme de laminé.

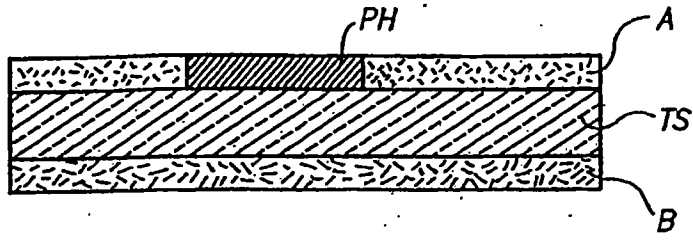

FIG. 1

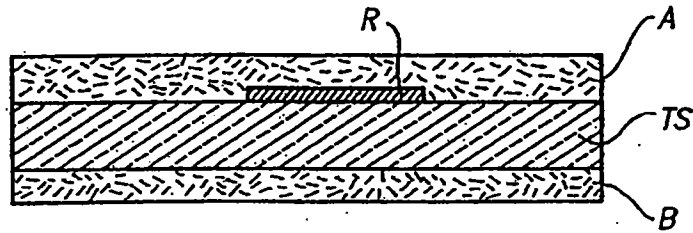

FIG. 2

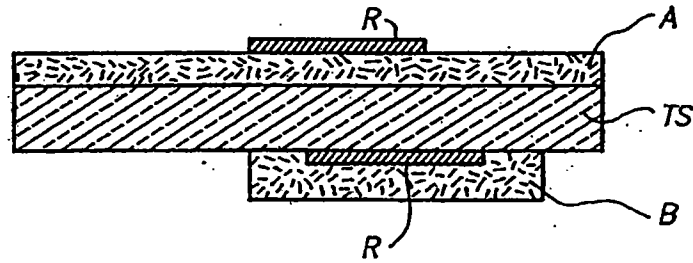

FIG. 3

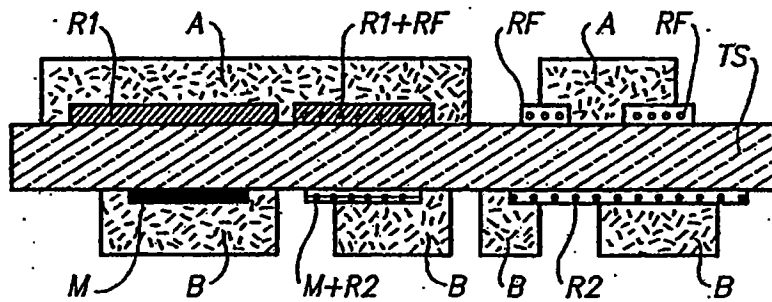

FIG. 4



(12) **NEW EUROPEAN PATENT SPECIFICATION**

(45) Date of publication and mention
of the opposition decision:
23.04.2003 Bulletin 2003/17

(51) Int CL⁷: B41M 3/14, G03C 5/08,
G03C 8/42, G03C 8/28,
G03C 8/52

(45) Mention of the grant of the patent:
30.07.1997 Bulletin 1997/31

(21) Application number: 93203473.9

(22) Date of filing: 10.12.1993

(54) **Security document having a transparent or translucent support and containing interference pigments.**

Sicherheitsdokument mit einem durchsichtigen oder durchscheinenden Träger und mit darin
enthaltenen Interferenzpigmenten

Document de sécurité ayant un support transparent ou translucide et contenant des pigments
d'interférence

(84) Designated Contracting States:
BE CH DE ES FR GB LJ NL

(43) Date of publication of application:
14.06.1995 Bulletin 1995/24

(73) Proprietors:
• AGFA-GEVAERT
2640 Mortsel (BE)
• NATIONALE BANK VAN BELGIE N.V.
1000 Brussel (BE)

(72) Inventors:
• Vermeulen, Leon
Septestraat 27, B-2640 Mortsel (BE)
• De Baets, Daniel
de Berlaimontlaan 14, B-1000 Brussel (BE)

(56) References cited:

EP-A- 0 317 514	EP-A- 0 490 825
EP-A- 0 518 740	EP-B- 0 071 160
EP-B- 0 303 725	DE-A- 3 810 015
DE-A- 4 141 069	DE-C- 62 053
FR-A- 2 429 292	GB-A- 202 702
GB-A- 2 035 587	US-A- 3 011 383
US-A- 4 428 997	

- PATENT ABSTRACTS OF JAPAN vol. 8, no. 210 (M-328)(1647) 26 September 1984 & JP-A-59 098 891 (DAINIPPON INSATSU) 7 June 1984
- PATENT ABSTRACTS OF JAPAN vol. 10, no. 115 (M-474)(2172) 30 April 1986 & JP-A-60 244 588 (KAZUHIRO NARA) 4 December 1985
- PATENT ABSTRACTS OF JAPAN vol. 10, no. 191 (M-495)(2247) 4 July 1986 & JP-A-61 035 985 (DAINICHI SEIKA) 20 February 1986
- "Optical Acta", 1983, vol. 20, No. 12, Seiten 925-937
- "Offsetdrucktechnik" by Helmut Teschner, seventh edition, 1990, Fachschriften-Verlag, Fellbach, ISBN 3-921217-14-8, pages 542ff. : "Densitometrische Messung"
- brochure "An introduction to digital scanning", published by Agfa-Gevaert N.V., 1994, NCUAV GB 00 199512, page 11: "Density formulas"
- "The Reproduction of Colour in Photography, Printing & Television" by R.W.G. Hunt, Fountain Press, England, fourth edition, 1987, ISBN 085242356 X, pages 70-71, p. 116 and pages 264-265

Description

1. Field of the Invention

5 [0001] The present invention relates to transparent security documents that can be verified on their authenticity and are protected against counterfeiting by photo-copying.

2. Background of the Invention

10 [0002] Security documents that must be verifiable on their authenticity are e.g. all kinds of identification documents such as passports, visas, identity cards, driver licenses, bank cards, credit cards, security entrance cards, and further value-documents such as banknotes, shares, bonds, certificates, cheques, lottery tickets and all kinds of entrance tickets such as airplane tickets and railroad season-tickets.

15 [0003] Nowadays, by the availability of markedly improved black-and-white and color copiers it becomes more and more easy to copy documents at high quality hardly to distinguish from the originals.

[0004] To protect the above mentioned documents against fraudulent alterations and reproduction by photo-copying different techniques are used such as the melt-laminating or glueing thereto of preprinted plastic overlayers; the printing with special inks; the application of coatings or layers for example loaded with magnetic or fluorescent pigments; coloring or metallizing the substrate of the documents; incorporating holograms; applying fine line printing, watermarks, 20 fibers, security threads, light diffraction marks, liquid crystal marks and/or substances called nacreous, iridescent or interference pigments.

[0005] In a particular case disclosed in US-P 4,151,666 light-transmissive pigments serving as diffuse reflectors are applied by printing to form a verification pattern in a laminated identification card (I.D. card). In the specification of the same US-P the use of nacreous pigments in verification patterns has been described. Nacreous pigments, also called 25 pearlescent pigments have light-reflection characteristics that change as a function of the viewing or copying angle. The effect of changing color with viewing angle makes that nacreous pigments represent a simple and convenient matter to built in a verification feature associated with a non-copyable optical property.

[0006] Interference pigments are in the form of light-reflecting crystal platelets of appropriate thickness to produce color by interference. These pigments exhibit a color play that verges on iridescence and under a given angle of reflection 30 will allow only the copying of a single color, whereas other colors appear under different angles of reflection, in other words these pigments show another color to the human eye depending on the observation angle. High nacreous luster is accompanied by high specular reflectance.

[0007] In most light interference pigments the transmission color is generally the complement of the reflection color.

35 [0008] Observed in transmission, some particular light interference pigments having more pronounced covering aspect show a particular greyish color while observed in reflection mode they have a more pronounced color-shift effect due to their specific built up and composition.

[0009] Transmission color of light interference pigments is much weaker than reflection color, which color seen in the reflection mode is called hereinafter "normal" color. [ref. Number 2 in a series of Mearl Technical Bulletins "Nacreous (Pearlescent) Pigments and Interference Pigments by L.M. Greenstein Henry L. Mattin Laboratories Reprinted from 40 Pigment Handbook, Vol. I, Properties and Economics; 2nd Edition, Edited by Peter A. Lewis, (1988) by permission of John Wiley & Sons, Inc. The Mearl Corporation, 41 East 42nd Street, New York, N.Y. 100017, p. 5 and 6].

[0010] In interference, the reflection and transmission colors vary with angle of incidence. The reflection maximum and minimum shift to lower wavelengths as the angle of incidence increases (ref. the above mentioned Mearl Technical Bulletin, p. 8. Variation in color with angle of incidence and observation is referred to as geometric metamerism or 45 gonio-chromatism [ref. Johnston, R. M. Color Eng., 5(3), 42-47, 54 (1967) and Hemmendinger, H. and Johnston R.M. "A Goniospectrophotometer for Color Measurements" in Color 69 (M. Richter. ed). Musterschmidt, Göttingen, Germany (1970)].

3. Objects and Summary of the Invention

50 [0011] It is an object of the present invention to provide a security document having a transparent support and containing through the presence of light interference pigments a verification feature that can not be copied by photographic techniques and wherein there is no need for specialized devices or conditions to verify the document on its authenticity.

55 [0012] It is a particular object of the present invention to provide a security document having a transparent support and containing at least one image or pattern in conjunction with interference pigments providing special effects that can not be copied photographically.

[0013] It is a special object of the present invention to provide a security document having a transparent support and comprising a layer including a photographically obtained portrait in conjunction with different light interference pigments

that allow easy verification by the naked eye of the security document involved.

[0014] Other objects and advantages of the present invention will become clear from the further description, drawings and examples.

[0015] In accordance with the present invention there is provided a security document as claimed in claim 1.

[0016] By "transparent support" in the document according to the present invention has to be understood a support having a visible light-blocking capacity less than 50 %, not being excluded supports that have obtained a color by incorporation of pigments.

4. Description of the drawings

[0017] Fig. 1 represents a schematic sectional drawing of a security document according to the present invention wherein light interference pigments A are present uniformly in a layer on one side of a transparent support TS and light interference pigments B different in color with respect to pigments A are present uniformly in a layer on the other side of said support and said document contains a photographically obtained image PH in the layer containing said pigments A.

[0018] Fig. 2 represents a schematic sectional drawing of a security document according to the present invention wherein light interference pigments A are present uniformly on one side of a transparent support TS and light interference pigments B different in color with respect to pigments A are present uniformly on the other side of said support, wherein the pigments A have underneath a pattern printed with "common" light reflecting pigments R having no light interference properties.

[0019] Fig. 3 represents a schematic sectional drawing of a security document according to the present invention wherein at one side of a transparent support TS a layer containing light interference pigments A has on top a printed pattern containing common light-reflecting pigments R. At the other side of said support a printed pattern containing said normal pigments R is overprinted with a pattern containing light interference pigments B.

[0020] Fig. 4 represents a schematic sectional drawing of a security document according to the present invention wherein patterns containing light interference pigments A at one side of a transparent support TS are printed over (1) a pattern containing "common" light reflecting pigments R1 of which the color is complementary to the color of said pigments A when seen with reflected light, (2) a pattern comprising "common" light reflecting pigments R1 mixed with colored fluorescent or phosphorescent pigments or dyes RF, and (3) patterns containing solely fluorescent or phosphorescent dyes that may be white by inspection with visible light but emit colored light when exposed to ultraviolet light. At the other side of said support TS light interference pigments B are printed over (1) an opaque pattern containing metallic pigments (aluminum or bronze flakes) M, (2) a pattern comprising metallic pigments M mixed with "common" light reflecting pigments R2 having a color complementary to the color of said light interference pigments B when seen with reflected light, and (3) a pattern comprising solely light reflecting pigments R2 having a color complementary to the color of said light interference pigments B when seen with reflected light.

5. Detailed Description of the Invention

[0021] A layer and/or pattern containing said light interference pigments (same or different) may be present at both sides of said transparent support.

[0022] The security document according to the present invention may contain in the same patterns and/or layer mixtures of different light interference pigments.

[0023] In a particular embodiment the support itself contains said light interference pigments and is produced e.g. by extruding a melt of a thermoplastic resin having homogeneously distributed therethrough one or more of said light interference pigments, or is produced by coating a resin solution having said pigment(s) dispersed therein followed after coating by the evaporation of the solvent(s) used.

[0024] An image or pattern present in said document may be formed by printing techniques including non-impact printing techniques and photographic techniques by which is understood herein that a visually inspectable image has been obtained in said document via a light-pattern transmitted or reflected by an original.

[0025] The document of the present invention by the presence of said interference pigments (including mixtures of said pigments) has at least in certain areas a different color when viewed with light transmitted by the document in comparison with light reflected by the document, and has at least in certain areas a different color when viewed in transmission mode from front or rear side. These properties form verification features that cannot be copied with common color copying machines and allow easy verification by the naked eye of the security document involved.

[0026] Preferred light interference pigments are titanium dioxide-coated mica or other metal-oxide coated pigments in which the metal oxide has preferably a refractive index comparable with the refractive index of TiO_2 , e.g. ZrO_2 , Fe_2O_3 or Cr_2O_3 .

[0027] The platelets of metal oxide coated mica pigments have three layers in such a way that on each of the broad

faces of the mica platelets a very thin coating of metal oxide is present.

[0028] The more brilliant interference pigments approach metallic luster, an effect that is enhanced by the presence of absorption colorants. TiO_2 -mica readily lends itself to incorporation of absorption colorants. Ferric oxide (Fe_2O_3) added to the TiO_2 layer, for example imparts a yellow color which in conjunction with a yellow interference color creates gold. When Fe_2O_3 is used in place of TiO_2 as the oxide coating on mica, these pigments have a yellow-red absorption color because of the inherent color of the Fe_2O_3 . They range from bronze to deep copper-red and have a metallic luster.

[0029] The preparation of such kind of pigments is described in the already mentioned bulletin "Nacreous (Pearlescent) Pigments and Interference Pigments", p. 3-4.

[0030] Mica pigments serving as a substrate of the interference coatings are a group of hydrous aluminum silicate minerals with platy morphology and perfect basal (micaceous) cleavage. Examples of suitable micas are e.g. muscovite $\text{KAl}_2(\text{AlSi}_3\text{O}_{10})(\text{OH})_2$, paragonite $\text{NaAl}_2(\text{AlSi}_3\text{O}_{10})(\text{OH})_2$, phlogopite $\text{K}(\text{Mg,Fe})(\text{AlSi}_3\text{O}_{10})(\text{OH})_2$, biotite $\text{K}(\text{Fe,Mg})(\text{AlSi}_3\text{O}_{10})(\text{OH})_2$ and lepidolite $\text{K}(\text{Li,Al})_2\text{Si}_3\text{O}_{10}(\text{Al}_{1.0-0.5}\text{Si}_{3.0-3.5}\text{O}_{10})(\text{OH})_2$ etc..

[0031] Details about the application of metal and/or metal oxide coatings on the mica platelets are further given in US-P 3,087,827, 4,434,010 and 5,059,245 and in published EP-A-45 851, EP-A-313 280, DE-A-11 65 182, DE-A-32 37 264, DE-A-38 25 702 and DE-A-36 17 430 and DE-OS 41 41 069.

[0032] In a preferred embodiment according to the present invention interference pigments having a composition as described in published German patent application DE-OS 41 41 069 are used. Said interference pigments, called "Glanzpigmente" according to said DE-OS are composed of silicate platelets coated with either:

- A) a first layer of highly refractive metal oxide, and
- B) a second black layer essentially consisting of metallic iron, molybdenum and/or wolfram, or coated with:

- A) a first layer of highly refractive metal oxide, and
- B) a second black layer essentially consisting of carbon or metal, and
- C) a third layer of highly refractive metal oxide.

[0033] By the presence of a semi-transparent carbon layer said platelets have a high chemical resistance. The carbon layer is obtained by thermal decomposition of oxygen-containing hydrocarbon compounds which for each two carbon atoms contain at least one oxygen atom e.g. as in carbohydrates such as sorbitol.

[0034] The metal layer B) can be formed in a medium of inert gas from in-gas-phase-decomposable metal compounds, e.g. metal carbonyl compounds, and the metal oxide layers A) and C) are formed by decomposition in gas phase of volatile metal compounds in the presence of oxygen water vapour or mixtures thereof.

[0035] The first layer A) consists e.g. of the oxides of titanium, zirconium, tin and/or iron.

[0036] Mica platelets double-side coated with one or more metal oxide layers for use as interference pigments are commercially available e.g. under the tradenames IRIODINE (E. Merck, Darmstadt), FLONAC (Kemira Oy, Porri, Finland), MEARLIN (The Mearl Corporation, New York, U.S.A.) and PALIOSECURE (BASF, Germany). Under these tradenames interference pigments showing violet, red, green, yellow and blue colors in reflected light at 90° are available on the market.

[0037] Holding an interference pigment-coated transparent support at 90° in a white light beam the transmitted light may be greyish-yellow to slightly brown which is a totally different color when seen in reflection (the main color). Such effect was seen as well in hydrophilic colloid coatings containing said pigments as in hydrophobic varnish layers. These differences of color in reflected and transmitted light cannot be photo-copied and form an easily detectable verification feature.

[0038] Moreover, looking at a coated blue interference pigment layer under different reflection angles the a blue color seen under a reflection angle of 90° will at a reflection angle smaller than 45° turn into yellow, green interference pigments obtain under these circumstances a greyish shade, whereas the violet and red pigments show a brownish-grey hue. In transparency inspection mode blue interference become brown yellow, magenta interference pigments turn green, and the green ones turn magenta.

[0039] Preferred interference platelet-type pigments for use according to the present invention have a largest surface diameter preferably between 5 and 200 μm and more preferably of 25 μm to 30 μm . The thickness of the platelet-type interference pigments is preferably between 0.1 μm and 0.6 μm and more preferably between 0.2 μm and 0.4 μm .

[0040] In order to obtain special verification effects under ultraviolet light exposure the interference pigments can be used in admixture with fluorescent or phosphorescent substances and optical brightening agents.

[0041] By way of example the light interference pigments A of the above drawings are blue light interference pigments such as PALIOSECURE (tradename of BASF - Germany) pigment code EC 1408 which shows when seen in reflection mode a vivid blue color. Seen in reflection their color changes in shade by changing the observation angle. When observed in transmission through said transparent-substrate said blue pigments change their hue and the color becomes complementary to blue, i.e. yellow, slightly darkened with a brown shade that is probably due to very small

impurities. A yellow light interference pigment such as IRIODINE (tradename of MERCK - Germany) pigment code 9331 has when observed in reflection mode a yellow color, seen in transmission the color of that pigment becomes complementary in color, i.e. blue. This is in accordance with the general property of light interference pigments of changing their color complementarily when changing their mode of viewing going from reflection to transmission mode.

5 [0042] Tests have been carried out in printing a security pattern on a transparent substrate in such a way that one part of a printing pattern was printed with blue light interference pigment (e.g. PALIOSECURE EC 1408 or FD 4187 of BASF - Germany) and another part was printed using a yellow interference pigment (e.g. IRIODINE 9231 of MERCK - Germany). By changing the viewing conditions from transmission to reflection mode the differently printed parts changed their color complementarily, so that the colors became inverted, which is as already been said, an effect that cannot be reproduced photographically by color copying machines. Common xerographic copying machines make prints against a white background (the color of the side of the cover of the machine contacting the original is white light reflecting). The light interference pigments that face the light source have high reflectance and show their normal color, whereas the "complementary" color is reproduced with transmitted light reflected by said cover.

10 [0043] Said property provides a strong security feature which makes e.g. that when a yellow light interference pigment background is surrounding an information pattern printed with a blue light interference pigment pattern a copying machine operating with transmitted light (that is reflected by its white cover) will provide a copy that has the printed information in yellow surrounded by a blue background which is the complementary in color from what can be seen directly in reflected light not passing through the document.

20 [0044] Further it has been found by us that when copying a transparent document printed with light interference pigments and overprinted with a fine guilloche design with common light reflecting pigment being no light interference pigment, the color of the guilloche pattern in the photocopy is different whether (1) the copy is made with the front side of the transparent document (original) directed towards the light source of the copying machine or (2) the copy is made with the light of said source directed through the rear of the transparent document towards the information pattern and image background at the front side receiving reflected light from the white light reflecting cover of the machine.

25 [0045] In the first case said "common" pigments contained in the guilloche pattern are reproduced with their inherent color and the light interference pigments are reproduced in the transmission mode in their complementary colors.

[0046] In the second case the photocopying machine does not see in reflected light the pattern of said "common" light reflecting pigments that have been printed on top of the light interference pigments so that they are not reproduced anymore, while the light interference pigments remain copied in their complementary color.

30 [0047] The "common" light reflecting pigments can be printed underneath or above the light interference pigments.

[0048] Thus, when in the above combination of information pattern and background a fine guilloche design having e.g. lines 3 microns wide, is printed with common yellow colored pigments (yellow light reflecting pigments) being no light interference pigments the differences between the copy and the original will become still more outspoken in that the color of the guilloche lines will be reproduced correctly but will not be detectable against the yellow pattern of light interference pigments seen by the copying machine.

35 [0049] In the embodiment illustrated in Fig. 3 the light reflecting pigments R can show a rainbow effect (are iridescent) wherein one of their rainbow colors has the same hue as the color of the light interference pigments being printed on top.

[0050] In the embodiment illustrated in Fig. 4 the light reflecting colors showing rainbow effect (often used in security documents) are used in a printing ink containing metallic powder (e.g. aluminium or bronze). Printed underneath the light interference pigments the metallic powder being opaque blocks light and prevents copying of information present on the other side of the transparent support. Opacifying front and back images may be printed on top and/or underneath the patterns containing light interference pigments. The printing on both sides of the transparent support may be in perfect front/back registration using a therefor adapted printing machine such as a "Simultan Press" which is known for printing security documents.

45 [0051] When the design of the document is arranged in such a way that the light interference pigment pattern does not cover completely the printing pattern of the light reflecting pigments underneath, the observation in reflective mode shows the light reflecting pigments in their own color on the front or rear side of the document in the non-covered zone only. In the covered zone the light interference pigments show in reflective mode their main color.

50 [0052] On inspection in transmission mode (holding the document to the light) or copying with transmitted light the patterns of common light-reflecting pigments from front and rear side of the document are added (combined) and may form an uninterrupted area in the field of light interference pigments showing their own complementary color or combination of said complementary colors in overlapping zones, which may result in a continuous grey area where the complementary colors each represent a complementary part of the visible spectrum, as is the case e.g. by having in congruency a zone containing yellow-reflecting light interference pigments and a zone containing blue-reflecting light interference pigments.

55 [0053] Light interference pigments may be mixed with fluorescent or phosphorescent pigments without blocking the light emitted thereby. Light interference pigments have always some transparency together with their high specular reflectance.

[0054] According to one embodiment the above mentioned photographically obtained image or pattern is produced by means of a black-and-white or colour developed photosensitive silver halide directly in a light-sensitive material itself or in a non-light-sensitive image receiving material having a transparent support.

5 [0055] According to another embodiment the above mentioned photographically obtained image or pattern is produced by means of a non-impact printing technique in which analog or digital input signals for controlling the printing of said image or pattern stem from light-information originating from a visible original, which light-information may be transformed into electrical signals that can be transduced and stored, e.g. on magnetic tape or optical disk. The visible original may be an object or living being or an already formed photograph of these.

10 [0056] A survey of non-impact printing techniques such as electro(photo)graphic printing, ink jet printing, photochemical printing and thermal transfer printing is given by Jerome L. Johnson in "Principles of Non Impact printing" Palatino Press - Irvine, California U.S.A. (1986).

[0057] In accordance with an embodiment according to the present invention there is provided a document including a photographically obtained image or pattern and uniformly distributed interference pigments of a particular color are present in the document in combination with a printed pattern containing interference pigments of a color different from the color of the uniformly distributed interference pigments.

15 [0058] In accordance with another embodiment according to the present invention there is provided a document including a photographically obtained image or pattern and having at each side of its transparent or translucent support a layer wherein interference pigments are distributed uniformly, and wherein said layers at opposite sides of said support have a different color by the presence of different interference pigments.

20 [0059] In accordance with a further embodiment according to the present invention there is provided a document wherein uniformly distributed interference pigments are present in combination with pattern-wise printed colored common light-reflecting pigments or dyes or white light reflecting pigments, e.g. TiO_2 . The color of the interference pigments under the copying angle is preferably the same as the color of said printed light-absorbing substances preventing thereby successful photocopying of the printed information that remains still readable by the human eye under another observation angle.

25 [0060] According to still another embodiment in a document of the present invention a pattern of printed interference pigments is present underneath and/or on top of a layer or support having a color substantially the same as the color of said pattern containing said interference pigments when seen in reflection or transmission mode.

30 [0061] According to an embodiment in the security document according to the present invention different interference pigments are present uniformly each in a different layer at opposite sides of said support and at least one of said layers has underneath and/or on top a pattern containing common light-reflecting pigments and/or dyes having no light interference properties, and having preferably a color substantially the same as the color of at least one of the interference pigments when seen in reflection or transmission mode.

35 [0062] According to another embodiment in the security document according to the present invention at least one pattern containing common light-reflecting pigments and/or dyes is present which pattern is at least partly covered with a pattern containing interference pigments.

40 [0063] According to a further embodiment in the document according to the present invention the support has been coated directly by sputtering with a thin metal oxide layer or has been coated with said metal oxide layer on top of a coating or pattern of said light interference pigments and/or coating or pattern of light reflecting pigments having no light interference properties taking care that the thus coated metal oxide layer has substantially the same or color complementary to the color of said patternwise applied pigments.

45 [0064] According to a special embodiment the document according to the present invention has on the front and/or rear side of its support underneath and/or on top thereof uniformly or patternwise applied interference pigments in the form of a printed guilloche line pattern with rainbow effect, containing therefor light reflecting pigments showing that effect so as to have one or more of the rainbow colors the same as the normal or complementary color of said light interference pigments. In a particular case said one or more of the rainbow colors is obtained by printing metallic pigments.

50 [0065] In another embodiment fluorescent or phosphorescent pigments have been mixed with said light interference pigments and/or with said light reflecting pigments giving said rainbow effect to the guilloche pattern or said rainbow effect is obtained by printing a transparent varnish loaded with a fluorescent or phosphorescent pigment.

55 [0066] According to a still further embodiment the document according to the present invention contains (a) bi-fluorescent pigment(s) that is (are) mixed with one of said light reflecting pigments and/or mixed with said light interference pigments whereby when exposed to ultraviolet light said fluorescent pigment(s) show(s) light of two different wavelength ranges one of which is different from the wavelength range of the colors of said light reflecting and interference pigments when these are observed under visible light conditions and the other corresponds with the normal or complementary color of said interference pigments.

[0067] In a particular embodiment a guilloche pattern with rainbow effect is printed in perfect see-through print register on the front and rear side of the support; the light reflecting pigments showing rainbow effect printed at one side have

complementary color with respect to the pigments printed; but have at one side a color the same as the normal color of said light interference pigments, and wherein parts of said guilloche pattern at either side cover at least partly a photograph or printed pattern or complete a printed pattern.

5 [0068] In a particularly interesting embodiment the document according to the present invention contains printed patterns at least partly covering each other and said patterns each contain (a) different light interference pigment(s) the construction and composition of which is such that they show a different color shift when viewed under the same observation angle, and wherein the printed pattern most remote from the observer has higher covering power than the pattern printed thereon which is more transparent, hereby obtaining a document that shows in the overlapping pattern area a continuously changing color shift by changing gradually the observation angle.

10 [0069] A layer containing uniformly distributed light interference pigments may be applied by coating a coating liquid containing said pigments in dispersed form and a dissolved binding agent or containing said pigments dispersed together with a binding agent in the form of a latex. After coating the solvent or dispersing liquid, e.g. water, is removed by evaporation. Any coating technique for the application of thin liquid layers may be used as is known e.g. from the field of the manufacture of photographic silver halide emulsion layer materials, e.g. doctor blade coating, gravure roller coating, meniscus coating, air knife coating, slide hopper coating and spraying.

15 [0070] According to a special coating technique the light interference pigments are applied in a radiation-curable binder or binder system wherein e.g. monomers act as solvent for polymers or prepolymers as described e.g. in published EP-A 0 522 609, so that after coating of the liquid coating composition no solvent has to be evaporated.

20 [0071] In accordance with a particular embodiment uniformly distributed interference pigments are applied in a layer that is transferred by a stripping-off procedure to build the document of the present invention. Such procedure is described in published EP-A 0 478 790 but is applied therein for controlling the whiteness of an image present on a permanent support using for the stripping-off and transfer procedure a temporary support coated with a wet-strippable non-photosensitive layer containing fluorescent whitening agent(s) in a hydrophilic colloid binder.

25 [0072] According to a special embodiment the light interference pigments are applied in the form of a pigment-transfer-foil wherefrom by hot transfer the pigments are transferred uniformly onto the substrate of the security document.

[0073] Still another coating technique suited for uniformly applying said pigments is by dry powder-spraying optionally on a hot-melt resin layer wherein they are impregnated by pressure and heat. On top of the pigments an adhesive, e.g. wax may be applied to improve adherence to the selected substrate. That substrate may have hydrophilic or hydrophobic surface properties.

30 [0074] Spray-coating may be applied for covering the whole surface of the substrate or only a part thereof producing "light interference rainbow-effects". By using varying mixtures of different interference pigments the intensity of one color can be made to decrease gradually while an increasing color intensity of another pigment comes up. The human eye will see the rainbow effect varying according to the perception angle and will recognize the basic color of each of the sprayed pigments, but a photocopier operating with a fixed copying angle will only reproduce, say a single yellowish-brown color and not the colors of the interference pigments that can be seen under different inspection angles.

35 [0075] The interference pigments can be used for pigmenting a commercial coating varnish which may then be used for pre-coating a security document substrate. The coating may proceed with common varnishing or impregnation machinery instead of using printing presses.

40 [0076] As already mentioned herein the uniformly applied interference pigments are advantageously combined with image-wise or pattern-wise applied interference pigments of another color.

[0077] The image-wise or pattern-wise application of interference pigments proceeds e.g. by printing with an ink containing said pigments. Suited printing processes are e.g. planographic offset printing, gravure printing, intaglio printing, screen printing, flexographic printing, relief printing, tampon printing, ink jet printing and toner-transfer printing from electro(photo)graphic recording materials.

45 [0078] For use in printing on hydrophilic layers or substrates the ink contains for example a 15 to 20 % by weight mixture of the interference pigments in a solution of cellulose nitrate in a polyethylene ether. Such ink has a good adherence on hydrophilic colloid layers such as gelatin-containing layers used in DTR-recording materials. Said ink is advantageously applied with a commercial screen press using a polyester screen with a 77 and 55 mesh. The interference colors gradually appear on drying the ink.

50 [0079] Thus applied ink patterns on a hydrophilic image-receiving layer for DTR-image production remain unchanged during DTR-processing.

[0080] The presence of the light interference pigments in one of the layers of the security document does not affect the possibility to print thereon further graphic or alpha-numerical information by any known printing technique.

55 [0081] For easy visual verification the light interference pigments are present preferably in a security document in a coverage of 0.3 g/m² to 10 g/m² and more preferably in a coverage between 0.7 g/m² and 3 g/m².

[0082] The printing of a light interference pigment-containing pattern may proceed on a substrate already covered e.g. by a hologram, light-diffraction pattern, metallic pattern that can be viewed through the printed pattern so that the properties of the interference pigments are added thereto.

[0083] The printed pattern containing interference pigments forms no obstacle for a good adherence with laminated plastic resinous covering material. By proper selection of the binder of the ink it can be co-melted with the resin material laminated thereto.

[0084] According to a particular embodiment the light interference pigment-containing ink is applied on a temporary support, e.g. polystyrene support, wherefrom the ink layer can be stripped off and transferred to a permanent support, e.g. a glued and preprinted substrate of a security document. The ink layer, applied overall or pattern-wise, after leaving the temporary support covers underlying pre-printed data on the permanent support. For preventing fraudulent copying these data have the same color as the interference pigment layer when seen under the copying angle. Insufficient image contrast is available so that copying of the pre-printed data is no longer possible. By applying a dried interference pigment-containing ink layer that is translucent the underlying data can be visually inspected therethrough by altering the perception angle.

[0085] In accordance with the preceding embodiment a security document according to the present invention, e.g. serving as I.D. card, is preferably in the form of a laminate in which the information-containing layer(s) are sealed between protective resinous sheets. I.D. card laminates may be built up as described e.g. in US-P 4,101,701, US-P 4,762,759, US-P 4,902,593, published EP-A 0 348 310 and published EP-A 0 462 330. By lamination tamper-proof documents are produced which do not allow the opening of the laminate without damaging the image contained therein. The destruction of the seal will leave visual fraude traces on the security document.

[0086] In accordance with a first mode in the security document according to the present invention a black-and-white photograph in the form of a silver image is formed by the silver salt diffusion transfer process, called herein DTR-process. According to said process dissolved silver halide salt is transferred imagewise in a special image receiving layer, called development nuclei containing layer, for reducing therein transferred silver salt, said development nuclei containing layer contains itself and/or in an overlying and/or an underlying layer uniformly distributed therein said interference pigments.

[0087] The light interference pigments may be present either in the image-receiving layer itself and/or in a waterpermeable top layer and/or in a subbing layer covering the support.

[0088] The presence of a dried water-impermeable ink pattern on the image-receiving layer blocks DTR-image formation. Thereby it is possible to arrange e.g. fine line patterns such as guilloches in the photograph creating that way an additional verification feature.

[0089] The principles of the DTR-process are described in U.S. patent No. 2,352,014 of André Rott, issued June 20, 1944. According to said process silver complexes are image-wise transferred by diffusion from a silver halide emulsion layer to an image-receiving layer, where they are converted, in the presence of development nuclei, into a silver image. For this purpose, an image-wise exposed silver halide emulsion layer is developed by means of a developing substance in the presence of a so-called silver halide solvent. In the exposed parts of the silver halide emulsion layer the silver halide is developed to metallic silver so that it cannot dissolve anymore and consequently cannot diffuse. In the non-exposed parts of the silver halide emulsion layer the silver halide is converted into soluble silver complexes by means of a silver halide complexing agent, acting as silver halide solvent, and said complexes are transferred by diffusion into an image-receiving layer being in waterpermeable contact with said emulsion layer to form by the catalytic action of said development nuclei, in so-called physical development, a silver-containing image in the image-receiving layer.

[0090] More details on the DTR-process can be found in "Photographic Silver Halide Diffusion Processes" by A. Rott and E. Weyde, Focal Press, London, New York (1972).

[0091] In accordance with a second mode in the security document according to the present invention a color photograph in the form of one or more dye images is formed by the dye diffusion transfer process (dye DTR-process) wherein the image-wise transfer of dye(s) is controlled by the development of (a) photo-exposed silver halide emulsion layer(s), and wherein dye(s) is (are) transferred imagewise in a special image receiving layer, called mordant layer, for fixing the dyes, said mordant layer and/or an overlying and/or an underlying layer containing uniformly distributed therethrough said interference pigments.

[0092] Dye diffusion transfer reversal processes are based on the image-wise transfer of diffusible dye molecules from an image-wise exposed silver halide emulsion material into a waterpermeable image-receiving layer containing a mordant for the dye(s). The image-wise diffusion of the dye(s) is controlled by the development of one or more image-wise exposed silver halide emulsion layers, that for the production of a multicolor image are differently spectrally sensitized and contain respectively a yellow, magenta and cyan dye molecules. A survey of dye diffusion transfer imaging processes has been given by Christian C. Van de Sande in Angew. Chem. - Ed. Engl. 22 (1983) n° 3, 191-209 and a particularly useful process is described in US-P 4,496,645.

[0093] For use in dye diffusion transfer photography the type of mordant chosen will depend upon the dye to be mordanted. If acid dyes are to be mordanted, the image-receiving layer being a dye-mordanting layer contains basic polymeric mordants such as polymers of amino-guanidine derivatives of vinyl methyl ketone such as described in US-P 2,882,156, and basic polymeric mordants and derivatives, e.g. poly-4-vinylpyridine, the metho-p-toluene sulphonate of poly-2-vinylpyridine and similar compounds described in US-P 2,484,430, and the compounds described in the

published DE-A 2,009,498 and 2,200,063. Other mordants are long-chain quaternary ammonium or phosphonium compounds or ternary sulphonium compounds, e.g. those described in US-P 3,271,147 and 3,271,148,, and cetyltrimethylammonium bromide. Certain metal salts and their hydroxides that form sparingly soluble compounds with the acid dyes may be used too. The dye mordants are dispersed or molecularly divided in one of the usual hydrophilic binders in the image-receiving layer, e.g. in gelatin, polyvinylpyrrolidone or partly or completely hydrolysed cellulose esters.

[0094] In US-P 4,186,014 cationic polymeric mordants are described that are particularly suited for fixing anionic dyes, e.g. sulphinic acid salt dyes that are image-wise released by a redox-reaction described e.g. in published EP-A 0,004,399 and US-P 4,232,107.

[0095] The DTR process can be utilized for reproducing line originals e.g. printed documents, as well as for reproducing continuous tone originals, e.g. portraits.

[0096] By the fact that the DTR-image is based on diffusion transfer of imaging ingredients the image-receiving layer and optionally present covering layer(s) have to be waterpermeable.

[0097] The reproduction of black-and-white continuous tone images by the DTR-process requires the use of a recording material capable of yielding images with considerable lower gradation than is normally applied in document reproduction to ensure the correct tone rendering of continuous tones of the original. In document reproduction silver halide emulsion materials are used which normally mainly contain silver chloride. Silver chloride not only leads to a more rapid development but also to high contrast.

[0098] In U.S. patent No. 3,985,561, to be read in conjunction herewith, a light-sensitive silver halide material is described wherein the silver halide is predominantly chloride and this material is capable of forming a continuous tone image on or in an image-receiving material by the diffusion transfer process.

[0099] According to said U.S. patent a continuous tone image is produced by the diffusion transfer process in or on an image-receiving layer through the use of a light-sensitive layer which contains a mixture of silver chloride and silver iodide and/or silver bromide dispersed in a hydrophilic colloid binder e.g. gelatin, wherein the silver chloride is present in an amount of at least 90 mole % based on the total mole of silver halide and wherein the weight ratio of hydrophilic colloid to silver halide, expressed as silver nitrate, is between 3:1 and about 10:1 by weight

[0100] With these light-sensitive materials successful reproduction of continuous tone images can be obtained probably as a result of the presence of the indicated amounts of silver iodide and/or silver bromide and of the defined high ratio of hydrophilic colloid to silver halide.

[0101] According to U.S. patent No. 4,242,436 likewise to be read in conjunction herewith, the reproduction of continuous tone images can be improved by developing the photographic material with a mixture of developing agents comprising an o-dihydroxybenzene, e.g. catechol, a 3-pyrazolidinone e.g. a 1-aryl-3-pyrazolidinone and optionally a p-dihydroxybenzene, e.g. hydroquinone, the molar amount of the o-dihydroxybenzene in said mixture being larger than the molar amount of the 3-pyrazolidinone, and the p-dihydroxybenzene if any being present in a molar ratio of at most 5 % with respect to the o-dihydroxybenzene.

[0102] Suitable development nuclei for use in the above mentioned physical development in the image receiving layer are e.g. noble metal nuclei e.g. silver, palladium, gold, platinum, sulphides, selenides or tellurides of heavy metals such as Pd, Ag, Ni and Co. Preferably used development nuclei are colloidal PdS, Ag₂S or mixed silver-nickelsulphide particles. The amount of nuclei used in the image receiving layer is preferably between 0.02 mg/m² and 10 mg/m².

[0103] The image receiving layer comprises for best imaging results the physical development nuclei in the presence of a protective hydrophilic colloid, e.g. gelatin and/or colloidal silica, polyvinyl alcohol etc..

[0104] The transfer behaviour of the complexed silver largely depends on the thickness of the image-receiving layer and the kind of binding agent or mixture of binding agents used in the nuclei containing layer. In order to obtain a sharp image with high spectral density the reduction of the silver salts diffusing into the image receiving layer must take place rapidly before lateral diffusion becomes substantial. An image-receiving material satisfying said purpose is described in US-P 4,859,566.

[0105] An image-receiving material of this type is very suitable for use in connection with the present invention and contains a water-impermeable support coated with (1) an image-receiving layer containing physical development nuclei and interference pigments dispersed in a waterpermeable binder and (2) a waterpermeable top layer free from development nuclei and containing a hydrophilic colloid, in such a way that

- (i) the total solids coverage of said two layers (1) and (2) is e.g. at most 2 g/m²,
- (ii) in layer (1) the coverage of the nuclei is in the range of 0.1 mg/m² to 10 mg/m², and the coverage of binder is in the range of 0.4 to 1.5 g/m², and
- (iii) in said top layer (2) the coverage of hydrophilic colloid is in the range of 0.1 to 0.9 g/m².

[0106] The coating of said layers proceeds preferably with slide hopper coater or curtain coater known to those skilled in the art.

[0107] According to a particular embodiment the nuclei containing layer (1) is present on a nuclei-free underlying hydrophilic colloid undercoat layer or undercoat layer system having a coverage in the range of 0.1 to 1 g/m² of hydrophilic colloid, the total solids coverage of layers (1) and (2) together with the undercoat being at most 2 g/m². In connection with this embodiment the nacreous pigments may be also be included in the undercoat layer or may be included therein instead of being present in the nuclei containing layer.

[0108] The undercoat optionally incorporates substances that improve the image quality, e.g. incorporates a substance improving the image-tone or the whiteness of the image background. For example, the undercoat may contain a fluorescent substance, silver complexing agent(s) and/or development inhibitor releasing compounds known for improving image sharpness.

[0109] According to a special embodiment the image-receiving layer (1) is applied on an undercoat playing the role of a timing layer in association with an acidic layer serving for the neutralization of alkali of the image-receiving layer. By the timing layer the time before neutralization occurs is established, at least in part, by the time it takes for the alkaline processing composition to penetrate through the timing layer. Materials suitable for neutralizing layers and timing layers are disclosed in Research Disclosure July 1974, item 12331 and July 1975, item 13525.

[0110] In the image-receiving layer (1) and/or in said top layer (2) and/or in an alkali-neutralizing undercoat gelatin is used preferably as hydrophilic colloid. In layer (1) gelatin is present preferably for at least 60 % by weight and is optionally used in conjunction with an other hydrophilic colloid, e.g. polyvinyl alcohol, cellulose derivatives, preferably carboxymethyl cellulose, dextran, galactomannans, alginate acid derivatives, e.g. alginate acid sodium salt and/or water-soluble polyacrylamides. Said other hydrophilic colloid may be used also in the top layer for at most 10 % by weight and in the undercoat in an amount lower than the gelatin content.

[0111] The image-receiving layer and/or a hydrophilic colloid layer in water-permeable relationship therewith may comprise a silver halide developing agent and/or silver halide solvent, e.g. sodium thiosulphate in an amount of approximately 0.1 g to approximately 4 g per m².

[0112] The image-receiving layer or a hydrophilic colloid layer in water-permeable relationship therewith may comprise colloidal silica.

[0113] The image-receiving layer may contain as physical development accelerators, in operative contact with the developing nuclei, thioether compounds such as those described e.g. in DE-A-1,124,354; US-P 4,013,471; US-P 4,072,526 and in EP 26520.

[0114] According to a preferred embodiment the processing liquid and/or the DTR image-receiving material contains at least one image toning agent. In said case the image toning agent(s) may gradually transfer by diffusion from said image-receiving material into the processing liquid and keep therein the concentration of said agents almost steady. In practice such can be realized by using the silver image toning agents in a coverage in the range from 1 mg/m² to 20 mg/m² in a hydrophilic waterpermeable colloid layer.

[0115] A survey of suitable toning agents is given in the above mentioned book of Andre Rott and Edith Weyde, p. 61-65, preference being given to 1-phenyl-1H-tetrazole-5-thiol, also called 1-phenyl-5-mercapto-tetrazole, tautomeric structures and derivatives thereof such as 1-(2,3-dimethylphenyl)-5-mercaptotetrazole, 1-(3,4-dimethylcyclohexyl)-5-mercapto-tetrazole, 1-(4-methylphenyl)-5-mercapto-tetrazole, 1-(3-chloro-4-methylphenyl)-5-mercapto-tetrazole, 1-(3,4-dichlorophenyl)-5-mercapto-tetrazole. Further particularly useful toning agents are of the class of thiohydantoins and of the class of phenyl substituted mercapto-triazoles. Still further toning agents suitable for use in accordance with the preferred embodiment of the present invention are the toning agents described in published European patent applications 218752, 208346, 218753 and US-P 4,683,189.

[0116] In the security documents according to the present invention the transparent support is e.g. a clear resin film support or such support containing small amounts of pigments or voids opacifying to some degree the support. For example, white TiO₂ particles as described e.g. in published European patent application (EP-A) 0 324 192 are incorporated therein.

[0117] Organic resins suited for manufacturing transparent film supports are e.g. polycarbonates, polyesters, preferably polyethylene terephthalate, polystyrene and homo- and copolymers of vinyl chloride. Further are mentioned cellulose esters e.g. cellulose triacetate.

[0118] The above mentioned DTR image-receiving materials may be used in conjunction with any type of photosensitive material containing a silver halide emulsion layer. For continuous tone reproduction the silver halide comprises preferably a mixture of silver chloride, and silver iodide and/or silver bromide, at least 90 mole % based on the total mole of the silver halide being silver chloride, and the ratio by weight of hydrophilic colloid to silver halide expressed as silver nitrate is between 3:1 and 10:1.

[0119] The binder for the silver halide emulsion layer and other optional layers contained on the imaging element is preferably gelatin. But instead of or together with gelatin, use can be made of one or more other natural and/or synthetic hydrophilic colloids, e.g. albumin, casein, zein, polyvinyl alcohol, alginate acids or salts thereof, cellulose derivatives such as carboxymethyl cellulose, modified gelatin, e.g. phthaloyl gelatin etc. The weight ratio in the silver halide emulsion layer of hydrophilic colloid binder to silver halide expressed as equivalent amount of silver nitrate to binder is e.

g. in the range of 1:1 to 10:1, but preferably for continuous tone reproduction is between 3.5:1 and 6.7:1.

[0120] The silver halide emulsions may be coarse or fine grain and can be prepared by any of the well known procedures e.g. single jet emulsions, double jet emulsions such as Uppmann emulsions, ammoniacal emulsions, thiocyanate- or thioether-ripened emulsions such as those described in US-P 2,222,264, 3,320,069, and 3,271,157. Surface image emulsions may be used or internal image emulsions may be used such as those described in US-P 2,592,250, 3,206,313, and 3,447,927. If desired, mixtures of surface and internal image emulsions may be used as described in US-P 2,996,382.

[0121] The silver halide particles of the photographic emulsions may have a regular crystalline form such as cubic or octahedral form or they may have a transition form. Regular-grain emulsions are described e.g. in J. Photogr. Sci., Vol. 12, No. 5, Sept./Oct. 1964, pp. 242-251. The silver halide grains may also have an almost spherical form or they may have a tabular form (so-called T-grains), or may have composite crystal forms comprising a mixture of regular and irregular crystalline forms. The silver halide grains may have a multilayered structure having a core and shell of different halide composition. Besides having a differently composed core and shell the silver halide grains may comprise also different halide compositions and metal dopants inbetween.

[0122] The average size expressed as the average diameter of the silver halide grains may range from 0.2 to 1.2 μm , preferably between 0.2 μm and 0.8 μm , and most preferably between 0.3 μm and 0.6 μm . The size distribution can be homodisperse or heterodisperse. A homodisperse size distribution is obtained when 95 % of the grains have a size that does not deviate more than 30 % from the average grain size.

[0123] The emulsions can be chemically sensitized e.g. by adding sulphur-containing compounds during the chemical ripening stage e.g. allyl isothiocyanate, allyl thiourea, and sodium thiosulphate. Also reducing agents e.g. the tin compounds described in BE-A 493,464 and 568,687, and polyamines such as diethylene triamine or derivatives of aminomethane-sulphonic acid can be used as chemical sensitizers. Other suitable chemical sensitizers are noble metals and noble metal compounds such as gold, platinum, palladium, iridium, ruthenium and rhodium. This method of chemical sensitization has been described in the article of R.KOSLOWSKY, Z. Wiss. Photogr. Photophys. Photochem. 46, 65-72 (1951).

[0124] The emulsions can also be sensitized with polyalkylene oxide derivatives, e.g. with polyethylene oxide having a molecular weight of 1000 to 20,000, or with condensation products of alkylene oxides and aliphatic alcohols, glycols, cyclic dehydration products of hexitols, alkyl-substituted phenols, aliphatic carboxylic acids, aliphatic amines, aliphatic diamines and amides. The condensation products have a molecular weight of at least 700, preferably of more than 1000. It is also possible to combine these sensitizers with each other as described in BE-P 537,278 and GB-P 727,982.

[0125] The silver halide emulsion may be sensitized panchromatically to ensure reproduction of all colors of the visible part of the spectrum or it may be orthochromatically sensitized.

[0126] The spectral photosensitivity of the silver halide can be adjusted by proper spectral sensitization by means of the usual mono- or polymethine dyes such as acidic or basic cyanines, hemicyanines, oxonols, hemioxonols, styryl dyes or others, also tri- or polynuclear methine dyes e.g. rhodacyanines or neocyanines. Such spectral sensitizers have been described by e.g. F.M. HAMER in "The Cyanine Dyes and Related Compounds" (1964) Interscience Publishers, John Wiley & Sons, New York.

[0127] The silver halide emulsions may contain the usual stabilizers e.g. homopolar or salt-like compounds of mercury with aromatic or heterocyclic rings such as mercaptotriazoles, simple mercury salts, sulphonium mercury double salts and other mercury compounds. Other suitable stabilizers are azalindenes, preferably tetra- or penta-azalindenes, especially those substituted with hydroxy or amino groups. Compounds of this kind have been described by BIRR in Z. Wiss. Photogr. Photophys. Photochem. 47, 2-27 (1952). Other suitable stabilizers are i.a. heterocyclic mercapto compounds e.g. phenylmercaptotetrazole, quaternary benzothiazole derivatives, and benzotriazole.

[0128] A survey of photographic silver halide emulsions and their preparation is given in Research Disclosure December 1989, item 308119.

[0129] Processing of the image-wise exposed photographic silver halide emulsion layer proceeds whilst in contact with an image receiving material according to the invention and is accomplished using an alkaline processing liquid having a pH preferably between 9 and 13. The pH of the alkaline processing liquid may be established using various alkaline substances. Suitable alkaline substances are inorganic alkali e.g. sodium hydroxide, potassium carbonate or alkanolamines or mixtures thereof. Preferably used alkanolamines are tertiary alkanolamines e.g. those described in EP-A-397925, EP-A-397926, EP-A-397927, EP-A-398435 and US-P 4,632,896. A combination of alkanolamines having both a pK_a above or below 9 or a combination of alkanolamines whereof at least one has a pK_a above 9 and another having a pK_a of 9 or less may also be used as disclosed in the Japanese patent applications laid open to the public numbers 73949/61, 73953/61, 169841/61, 212670/60, 73950/61, 73952/61, 102644/61, 226647/63, 229453/63, US-P-4,362,811, US-P 4,568,634 etc.. The concentration of these alkanolamines is preferably from 0.1 mol/l to 0.9 mol/l.

[0130] Suitable developing agents for the exposed silver halide are e.g. hydroquinone-type and 1-phenyl-3-pyrazolidone-type developing agents as well as p-monomethylaminophenol and derivatives thereof. Preferably used is a combination of a hydroquinone-type and 1-phenyl-3-pyrazolidone-type developing agent wherein the latter is preferably

incorporated in one of the layers comprised on the support of the photographic material. A preferred class of 1-phenyl-3-pyrazolidone-type developing agents is disclosed in the published EP-A 449340.

[0131] According to a preferred embodiment for continuous tone reproduction a mixture of developing agents comprising an o-dihydroxybenzene, e.g. catechol, a 3-pyrazolidinone e.g. a 1-aryl-3-pyrazolidinone and optionally a p-dihydroxybenzene, e.g. hydroquinone the molar amount of the o-dihydroxybenzene in said mixture being larger than the molar amount of the 3-pyrazolidinone, and the p-dihydroxybenzene if any being present in a molar ratio of at most 5% with respect to the o-dihydroxybenzene can be used. Other type of developing agents suitable for use in accordance with the present invention are reductones e.g. ascorbic acid derivatives.

[0132] The developing agent or a mixture of developing agents can be present in an alkaline processing solution, in the photographic material or the image receiving material. In case the developing agent or a mixture of developing agents is contained in the photographic material and/or image receiving material, the processing solution can be merely an aqueous alkaline solution that initiates and activates the development.

[0133] In the DTR process the photographic element is developed in the presence of a silver halide solvent. Preferably used silver halide solvents are water soluble thiosulphate compounds such as ammonium and sodium thiosulphate, or ammonium and alkali metal thiocyanates. Other useful silver halide solvents (or "complexing agents") are described in the book "The Theory of the Photographic Process" edited by T.H. James, 4th edition, p. 474-475 (1977), in particular sulphites and uracil. Further interesting silver halide complexing agents are cyclic imides, preferably combined with alkanolamines, as described in US-P 4,297,430 and US-P 4,355,090. 2-mercaptobenzoic acid derivatives are described as silver halide solvents in US-P 4,297,429, preferably combined with alkanolamines or with cyclic imides and alkanolamines. Dialkylmethylenedisulfones can also be used as silver halide solvent.

[0134] The silver halide solvent is preferably present in the processing solution but may also be present in one or more layers comprised on the support of the imaging element and/or receiving material. When the silver halide solvent is incorporated in the photographic material it may be incorporated as a silver halide solvent precursor as disclosed in e.g. Japanese published unexamined patent applications no. 15247/59 and 271345/63, US-P 4,693,955 and US-P 3,685,991.

[0135] The processing solution for use in the production of black-and-white photographs in security documents according to the present invention may comprise other additives such as e.g. thickeners, preservatives, detergents e.g. acetylenic detergents such as SURFYNOL 104, SURFYNOL 465, SURFYNOL 440 etc. all available from Air Reduction Chemical Company, New York.

[0136] The DTR-process is normally carried out at a temperature in the range of 10°C to 35°C.

[0137] Further details about the black-and-white DTR process and also about the dye diffusion transfer process and image receiving materials used therein are described in Research Disclosure November 1976, item 15162.

[0138] The present invention will now be illustrated by the following examples without however limiting it thereto. All ratios, percentages and parts are by weight unless otherwise specified.

EXAMPLE 1

- Preparation of photographic element for use in the DTR process

[0139] A gelatino silver halide emulsion was prepared by slowly running with stirring an aqueous solution of 1 mole of silver nitrate per liter into a gelatine solution containing per mole of silver nitrate 41 g of gelatin, 1.2 mole of sodium chloride, 0.08 mole of potassium bromide and 0.01 mole of potassium iodide.

[0140] The temperature during precipitation and the subsequent ripening process lasting three hours was kept at 40°C.

[0141] Before cooling, shredding and washing 214 g of gelatin were added per mole of silver halide. The washed noodles were molten and another 476 g of gelatin were added per mole of silver halide during the chemical ripening. After ripening 285 g of gelatin in the form of a 20% aqueous solution were added to the emulsion per mole of silver halide as well as hydroquinone in an amount such that after coating 0.9 g of hydroquinone were present per m² and 1-phenyl-4,4-dimethyl-3-pyrazolidinone in an amount such that 0.21 g thereof were present per m². The emulsion was coated at one side of a subbed water-resistant paper support consisting of a paper having a weight of 110 g/m² coated at both sides with a polyethylene stratum at a ratio of 20 g/m² per side.

[0142] The emulsion was coated in such a way that an amount of silver equivalent to 1.5 g of silver nitrate was applied per m². The amount of gelatin corresponding therewith is 8.93 g/m² since the gelatin to silver nitrate weight ratio was 5.97.

- Preparation of image receiving material for use in the DTR process and containing light interference pigments

[0143] One side of a double-side subbed transparent polyethylene terephthalate support having a thickness of 0.1

mm was coated after corona treatment at a dry coverage of 2.5 g/m² of gelatin and 1.3 g/m² of interference pigment from the following coating composition:

5	carboxymethyl cellulose	12 g
	gelatin	38.5 g
	3 % aqueous dispersion of colloidal Ag ₂ S.NIS nuclei	14 ml
	4 % aqueous solution of formaldehyde	12 ml
10	aqueous dispersion of blue PALIOSECURE type EC 1408 (tradename) containing 30 % of said blue pigment and 8 % of gelatin	80 g
	12.5 % solution of saponine in ethanol/water (20/80)	20 ml

[0144] The other side of said support was coated with the above mentioned image-receiving layer coating composition, with the difference however, that the blue interference pigment PALIOSECURE type EC 1408 (tradename) pigment was replaced by yellow interference pigment IRIODINE 9231 (tradename).

- Printing of the image receiving material with pattern of graphical and numerical information using a blue non-iridescent ink

[0145] The printing of said information was carried out in the background area having a yellow color (on observation in reflection mode) due to the presence of said interference pigment IRIODINE 9231 (tradename).

DTR-image formation

[0146] The above defined photographic element was image-wise exposed in a reflex camera to obtain therein a photograph (portrait) of the passport owner.

[0147] The photo-exposed element was pre-moistened with a processing liquid as defined hereinafter.

[0148] The contact time of the photo-exposed element with said liquid was 6 seconds before being pressed together with the image-receiving material at the blue-pigment side as defined above. The transfer processor employed was a COPYPROOF (registered trade name of AGFA-GEVAERT N.V) type CP 380. The transfer contact time was 30 seconds. In the image-receiving layer a positive black-and-white (silver image) portrait of the photographed person was obtained.

- Composition of the processing liquid:

[0149]

40	hydroxyethyl cellulose	1.0 g
	Ethyl enediaminetetraacetic acid tetrasodium salt	2.0 g
	Na ₂ SO ₃	45.0 g
	Na ₂ S ₂ O ₃	14.0 g
	KBr	0.5 g
	1-Phenyl-5-mercapto-tetrazole	0.1 g
45	1-(3,4-Dichlorophenyl)-1H-tetrazole-5-thiol	0.02 g
	N-methyl-ethanolamine	45.0 ml
	N-methyl-diethanolamine	30.0 ml
	Water up to	1 l

[0150] When viewed in daylight under an angle of 90° in reflection mode the color of the non-printed area around the portrait (inspection at the front side) was blue due the presence of uniformly distributed therein PALIOSECURE type EC 1408 - BLUE (tradename). In the transmission mode the color in that background area became slightly brownish yellow at the front side and blue at the rear side.

[0151] On copying the obtained document with a color copier (CANON CLC 500) the parts of the document around the portrait were reproduced grey (yellow plus blue) having the blue printed graphical information of non-iridescent pigment with poor contrast thereon.

EXAMPLE 2

- Preparation of image-receiving element for use in dye diffusion transfer process

5 [0152] A transparent polyvinyl chloride sheet having a thickness of 0.100 mm was after corona treatment coated at one side with the following compositions for forming a subbing layer and mordanting layer respectively:

1. Subbing layer coating composition

10 [0153]

gelatin	4 g
aqueous dispersion of blue PALJOSECURE type EC 1408 (tradename) containing 30 % of said blue pigment and 8 % of gelatin	200 g
Ingredient A 40 % solution dispersed in aqueous medium	250 ml
5 % solution of siloxane compound in ethanol	125 ml
12.5 % solution of saponine in ethanol/water 20/80	20 ml

20 [0154] Ingredient A is a polyester-polyurethane having the same chemical composition as described in US-P 4,902,593, column 2, lines 64-68 and column 3, lines 1-8.

[0155] The coating composition was applied coated at a dry coverage of 0.4 g/m² of gelatin and 1.2 g of interference pigment.

25 2. Coating composition of the mordanting layer

[0156]

gelatin	20 g
mordant M (20 % solution)	250 ml
saponine (12 %) and wetting agent W (5 %) in water	32 ml
aqueous 4 % solution of formaldehyde	10 ml

35 [0157] Mordant M on the basis of an epoxidized cationic polymer has the same composition as described in US-P 4,902,593, column 7, lines 14-42.

[0158] The coating composition was applied at a dry coverage of 0.9 g/m² of gelatin.

[0159] The other side of said support was coated with the above mentioned image-receiving layer coating composition, with the difference however, that the blue interference pigment PALJOSECURE type EC 1408 (tradename) pigment was replaced by yellow interference pigment IRIODINE 9231 (tradename).

40 [0160] The above defined image-receiving material was processed in combination with a photographic dye diffusion transfer material as described in the Example of U.S. Pat. No. 4,496,645, which material was exposed to reproduce thereon a portrait. The exposed material was kept for 1 minute in contact with the above defined image-receiving material after being led through a diffusion transfer apparatus COPYPROOF CP 38 (tradename of Agfa-Gevaert N.V. Belgium) having in its tray the following basic processing liquid :

sodium hydroxide	25 g
sodium orthophosphate	25 g
cyclohexane dimethanol	25 g
2,2' methylpropylpropane diol	25 g
N-ethylbenzene-pyridinium chloride	0.5 g
distilled water up to	1000 ml

55 [0161] After leaving the processing tray the image-receiving sheet was led through a second tray containing an aqueous solution of the already mentioned wetting agent W corresponding with the following formula : iso-nonyl-phenoxy-(CH₂-CH₂-O)₉-H and potassium iodide (ref. EP 0250657).

[0162] After drying the processed sheet material it was laminated as described in US-P 4,902,593 to obtain a sealed

I.D. card.

EXAMPLE 3

5 [0163] The interference pigments mentioned in Example 2 were applied uniformly in front and rear mordanting layers respectively instead of in the subbing layers of an image-receiving material suited for use in a dye diffusion transfer process.

- Preparation of the image-receiving element

10 [0164] A transparent polyvinyl chloride sheet having a thickness of 0.100 mm was after corona treatment coated at one side with the following compositions for forming a subbing layer and mordanting layer respectively

1. Coating composition of the subbing layer

15

[0165]

gelatin	20 g
Ingredient A 40 % solution dispersed in aqueous medium	250 ml
5 % solution of siloxane compound in ethanol	125 ml
12.5 % solution of saponine in ethanol/water 20/80	20 ml

20

[0166] The coating composition was applied coated at a dry coverage of 0.4 g/m² of gelatin.

25

2. Coating composition of the front mordanting layer

[0167]

gelatin	12 g
aqueous dispersion of blue PALIOSECURE type EC 1408 (tradename) containing 30 % of said blue pigment and 8 % of gelatin	100 g
mordant M (20 % solution)	250 ml
saponine (12 %) and wetting agent W (5 %) in water	32 ml
aqueous 4 % solution of formaldehyde	10 ml

30

35

3. Coating composition of the rear mordanting layer

40

[0168]

gelatin	12 g
aqueous dispersion of yellow IRIODINE 9231 (tradename) containing 30 % of yellow pigment and 8 % of gelatin	100 g
mordant M (20 % solution)	250 ml
saponine (12 %) and wetting agent W (5 %) in water	32 ml
aqueous 4 % solution of formaldehyde	10 ml

45

[0169] The coating composition was applied at a dry coverage of 0.9 g/m² of gelatin, and 1.3 g/m² of interference pigment.

50

EXAMPLE 4

55 [0170] Example 3 was repeated with the difference that the light interference pigments were applied uniformly in a gelatin top coat covering the mordanting layer. The dried top coat contained 0.5 g/m² of gelatin and 1.3 g/m² of interference pigment at each side of the transparent support.

Claims

1. A security document which contains at least one layer, a support, at least one image or pattern serving for identification purposes and at least one light interference pigment distributed uniformly or patternwise in or on at least one layer of said document, characterized in that said support is a transparent clear resin film support or such support containing small amounts of pigments or voids opacifying to some degree the support, with a visible light-blocking capacity less than 50 % and in that said document, by the presence of said light interference pigment, has at least in certain areas a different color when viewed with light transmitted by the document in comparison with light reflected by the document.
2. Document according to claim 1, wherein said document contains mixtures of different light interference pigments.
3. Document according to claim 1 or 2, wherein in said document different light interference pigments are present uniformly each in a different layer at opposite sides of said support.
4. Document according to claim 1 or 2, wherein in said document different interference pigments are present uniformly each in a different layer at opposite sides of said support and at least one of said layers has underneath and/or on top a pattern containing common light-reflecting pigments and/or dyes having no light interference properties.
5. Document according to claim 4, wherein said pattern has substantially the same color as the color seen in transmission mode or reflection mode of the light interference pigments combined with said pattern.
6. Document according to claim 1 or 2, wherein pattern-wise printed interference pigments are present underneath and/or on top of a pattern containing common light-reflecting pigments and/or dyes having no light interference properties.
7. Document according to claim 1 or 2, wherein a pattern of printed interference pigments is present underneath and/or on top of a layer or support having a color substantially the same as the color of said pattern containing said interference pigments when seen in reflection or transmission mode.
8. Document according to claim 1 or 2, wherein printed information containing light interference pigments A having underneath printed information containing normal light-absorbing and light-reflecting pigments R are present at one side of a transparent support TS and at the other side of said support said normal pigments R are printed in a pattern being overprinted at least partly by a pattern containing light interference pigments B.
9. Document according to claim 1 or 2, wherein information containing light interference pigments A at one side of a transparent support TS is patternwise printed over (1) a "common" light reflecting pigment pattern R1 of which the color is complementary to the color of said pigments A when seen with reflected light, (2) a pigment pattern comprising "common" light reflecting pigments R1 mixed with colored fluorescent or phosphorescent pigments or dyes RF, and at the other side of said support TS interference pigments B are printed over (1') a metallic pigment (aluminium or bronze platelets) pattern M, (2') a pattern comprising light reflecting pigments R2 having a color complementary to the color of said pigments B when seen with reflected light, (3') a pattern comprising metallic pigments M mixed with "common" light reflecting pigments R2 having a color complementary to the color of said pigments B when seen with reflected light.
10. Document according to any of the preceding claims, wherein said document contains a photographically obtained image or pattern.
11. Document according to claim 10, wherein said photographically obtained image or pattern is produced by means of developed photosensitive silver halide directly in a light-sensitive material itself or in a non-light-sensitive image receiving material.
12. Document according claim 10, wherein said photographically obtained image or pattern is produced by means of a non-impact printing technique in which analog or digital input signals for controlling said printing stem from photo-signals originating from a visible original.
13. Document according to claim 10, wherein said photographically produced image or pattern is formed by the silver salt diffusion transfer process in an image-receiving material containing an image receiving layer comprising de-

velopment nuclei.

- 5
14. Document according to claim 10, wherein said photographically produced image or pattern is formed by a dye diffusion transfer process in an image-receiving material containing a mordant for a dye transferred from an image-wise exposed and developed silver halide emulsion material.
15. Document according according to any of the preceding claims, wherein said interference pigments are mica platelets coated with a metal oxide.
- 10
16. Document according to claim 15, wherein said metal oxide is selected from the group consisting of TiO_2 , ZrO_2 , Fe_2O_3 and Cr_2O_3 .
17. Document according to claim 15 or 16, wherein said platelets coated with said metal oxide have a second coating of carbon.
- 15
18. Document according to any of claims 15 to 17, wherein said platelets have a largest surface diameter between 5 and 200 μm .
19. Document according to any of claims 15 to 18, wherein the thickness of said interference pigments is between 0.1 and 0.6 μm .
- 20
20. Document according to any of the preceding claims, wherein said light interference pigments are present in said document in a coverage of 0.3 g/m^2 to 10 g/m^2 .
- 25
21. Document according to any of the preceding claims, wherein said support has been coated directly by sputtering with a thin metal oxide layer or has been coated with said metal oxide layer on top of a coating or pattern of said light interference pigments and/or coating or pattern of light reflecting pigments having no light interference properties taking care that the thus coated metal oxide layer has substantially the same or color complementary to the color of said patternwise applied pigments.
- 30
22. Document according to any of the preceding claims, wherein on the front and/or rear side of said support underneath and/or on top of uniformly or patternwise applied interference pigments a printed guilloche line pattern with rainbow effect is present, containing therefor light reflecting pigments showing that effect so as to have one or more of the rainbow colors the same as the normal or complementary color of said light interference pigments.
- 35
23. Document according to claim 22, wherein one or more of the rainbow colors is obtained by printing metallic pigments.
- 40
24. Document according to claim 22, wherein fluorescent or phosphorescent pigments have been mixed with said light interference pigments and/or with said light reflecting pigments giving said rainbow effect to the guilloche pattern.
25. Document according to claim 22, wherein said rainbow effect is obtained by printing a transparent varnish loaded with a fluorescent or phosphorescent pigment.
- 45
26. Document according to claim 22, wherein (a) bi-fluorescent pigment(s) is (are) mixed with one of said light reflecting pigments and/or mixed with said light interference pigments whereby when exposed to ultraviolet light said fluorescent pigment(s) show(s) light of two different wavelength ranges one of which is different from the wavelength range of the colors of said light reflecting and interference pigments when these are observed under visible light conditions and the other corresponds with the normal or complementary color of said interference pigments.
- 50
27. Document according to any of the preceding claims, wherein a guilloche pattern with rainbow effect is printed in perfect see-through print register on the front and rear side of said support, and wherein the light reflecting pigments showing rainbow effect printed at one side have complementary color with respect to the pigments printed, but have at one side a color the same as the normal color of said light interference pigments, and wherein parts of said guilloche pattern at either side cover at least partly a photograph or printed pattern or complete a printed pattern.
- 55
28. Document according to any of the preceding claims, wherein said document contains printed patterns at least

partly covering each other and said patterns each contain (a) different light interference pigment(s) the construction and composition of which is such that they show a different color shift when viewed under the same observation angle, and wherein the printed pattern most remote from the observer has higher covering power than the pattern printed thereon which is more transparent, hereby obtaining a document that shows in the overlapping pattern area a continuously changing color shift by changing gradually the observation angle.

29. Document according to any of the preceding claims, wherein said document is in the form of a laminate.

10 Patentansprüche

1. Ein Sicherheitsdokument, das wenigstens eine Schicht, einen Träger, wenigstens ein zu Identifikationszwecken dienendes Bild oder Muster und wenigstens ein gleichmäßig oder mustermäßig in oder auf wenigstens einer Schicht dieses Dokuments verteiltes Lichtinterferenzpigment enthält, dadurch gekennzeichnet, daß der Träger ein durchsichtiger klarer Harzfilmträger oder ein solcher, kleine Mengen des Träger einigermaßen trübmachende Pigmente oder Hohlräumen enthaltender Träger mit einer Lichtundurchlässigkeit für sichtbares Licht kleiner als 50% ist, und dadurch, daß das Dokument aufgrund der Einarbeitung des Lichtinterferenzpigments bei Betrachtung mit durch das Dokument durchgelassenem Licht im Vergleich mit einer Betrachtung mit durch das Dokument reflektiertem Licht wenigstens in bestimmten Bereichen eine unterschiedliche Farbe aufweist.
2. Dokument nach Anspruch 1, dadurch gekennzeichnet, daß das Dokument Mischungen aus verschiedenen Lichtinterferenzpigmenten enthält.
3. Dokument nach Anspruch 1 oder 2, dadurch gekennzeichnet, daß in diesem Dokument verschiedene Lichtinterferenzpigmente je gleichmäßig in einer unterschiedlichen, an den gegenüberliegenden Seiten des Trägers befindlichen Schicht enthalten sind.
4. Dokument nach Anspruch 1 oder 2, dadurch gekennzeichnet, daß in diesem Dokument verschiedene Lichtinterferenzpigmente je gleichmäßig in einer unterschiedlichen, an den gegenüberliegenden Seiten des Trägers befindlichen Schicht enthalten sind und wenigstens eine dieser Schichten auf deren Unterseite und/oder Oberseite ein Muster mit üblichen lichtreflektierenden Pigmenten und/oder Farbstoffen ohne Lichtinterferenzeigenschaften enthält.
5. Dokument nach Anspruch 4, dadurch gekennzeichnet, daß das Muster wesentlich dieselbe Farbe hat wie die Farbe, die bei der Durchsicht- oder Aufsichtbetrachtung der Lichtinterferenzpigmente in Kombination mit diesem Muster beobachtet wird.
6. Dokument nach Anspruch 1 oder 2, dadurch gekennzeichnet, daß unter und/oder auf einem Muster mit üblichen lichtreflektierenden Pigmenten und/oder Farbstoffen ohne Lichtinterferenzeigenschaften mustermäßig gedruckte Interferenzpigmente enthalten sind.
7. Dokument nach Anspruch 1 oder 2, dadurch gekennzeichnet, daß unter und/oder auf einer Schicht oder einem Träger ein Muster von gedruckten Interferenzpigmenten enthalten ist, wobei die Schicht bzw. der Träger bei Durchsicht- oder Aufsichtbetrachtung wesentlich dieselbe Farbe wie die Farbe des die Interferenzpigmente enthaltenden Musters aufweist.
8. Dokument nach Anspruch 1 oder 2, dadurch gekennzeichnet, daß gedruckte Information enthaltende Lichtinterferenzpigmente A, unter denen sich gedruckte Information enthaltende, normale, lichtabsorbierende und lichtreflektierende Pigmente R befinden, auf einer Seite eines durchsichtigen Trägers TS enthalten sind und auf der anderen Seite des Trägers die normalen Pigmente R in einem wenigstens teilweise durch ein Lichtinterferenzpigmente B enthaltendes Muster überdruckten Muster gedruckt werden.
9. Dokument nach Anspruch 1 oder 2, dadurch gekennzeichnet, daß Information enthaltende Lichtinterferenzpigmente A auf einer Seite eines durchsichtigen Trägers TS mustermäßig über (1) einem "üblichen" lichtreflektierenden Pigmente R1 enthaltenden Muster, deren Farbe bei Aufsichtbetrachtung mit der Farbe der Pigmente A komplementär ist, und (2) einem Pigmentmuster mit "üblichen" lichtreflektierenden, mit gefärbten fluoreszierenden oder phosphoreszierenden Pigmenten oder Farbstoffen RF vermischten Pigmenten R1 gedruckt werden und auf der anderen Seite des Trägers TS Interferenzpigmente B über (1) einem Metallpigmente (Aluminium- oder Bronze-

platten) enthaltenden Muster M, (2') einem Muster mit lichtreflektierenden Pigmenten R2, die bei Aufsichtbetrachtung eine mit der Farbe der Pigmente B komplementäre Farbe aufweisen, und (3') einem Muster mit Metallpigmenten M, die mit "normalen" lichtreflektierenden Pigmenten R2, die bei Aufsichtbetrachtung eine mit der Farbe der Pigmente B komplementäre Farbe aufweisen, vermischt sind, gedruckt werden.

5

10. Dokument nach irgendeinem der vorstehenden Ansprüche, dadurch gekennzeichnet, daß das Dokument ein fotografisch erhaltenes Bild oder Muster enthält.

10

11. Dokument nach Anspruch 10, dadurch gekennzeichnet, daß das fotografisch erhaltene Bild oder Muster unter Anwendung von entwickeltem fotoempfindlichem Silberhalogenid direkt in einem lichtempfindlichen Material selber oder in einem lichtunempfindlichen Bildempfangsmaterial erzeugt wird.

15

12. Dokument nach Anspruch 10, dadurch gekennzeichnet, daß das fotografisch erhaltene Bild oder Muster durch eine anschlagnfreie Drucktechnik, bei der analoge oder digitale, den Druckvorgang steuernde Eingangssignale von durch eine sichtbare Vorlage emittierten Fotosignalen stammen, erzeugt wird.

20

13. Dokument nach Anspruch 10, dadurch gekennzeichnet, daß das fotografisch erzeugte Bild oder Muster gemäß dem Silbersatzdiffusionsübertragungsverfahren in einem Bildempfangsmaterial mit einer Entwicklungseine enthaltenden Bildempfangsschicht erzeugt wird.

25

14. Dokument nach Anspruch 10, dadurch gekennzeichnet, daß das fotografisch erzeugte Bild oder Muster entsprechend einem Farbstoffdiffusionsübertragungsverfahren in einem Bildempfangsmaterial, das ein Beizmittel für einen von einem bildmäßig belichteten und entwickelten Silberhalogenidemulsionsmaterial übertragenen Farbstoff enthält, erhalten wird.

30

15. Dokument nach irgendeinem der vorstehenden Ansprüche, dadurch gekennzeichnet, daß die Interferenzpigmente mit einem Metalloxid überzogene Mikaplatten sind.

16. Dokument nach Anspruch 15, dadurch gekennzeichnet, daß das Metalloxid TiO_2 , ZrO_2 , Fe_2O_3 oder Cr_2O_3 ist.

35

17. Dokument nach Anspruch 15 oder 16, dadurch gekennzeichnet, daß die mit dem Metalloxid überzogenen Platten eine zweite, aus Kohlenstoff bestehende Schicht haben.

18. Dokument nach irgendeinem der Ansprüche 15 bis 17, dadurch gekennzeichnet, daß der Höchstoberflächendurchmesser der Platten zwischen 5 und 200 μm liegt.

40

19. Dokument nach irgendeinem der Ansprüche 15 bis 18, dadurch gekennzeichnet, daß die Stärke der Interferenzpigmente zwischen 0,1 und 0,6 μm liegt.

20. Dokument nach irgendeinem der vorstehenden Ansprüche, dadurch gekennzeichnet, daß die Lichtinterferenzpigmente in einem Verhältnis zwischen 0,3 g/m^2 und 10 g/m^2 im Dokument enthalten sind.

45

21. Dokument nach irgendeinem der vorstehenden Ansprüche, dadurch gekennzeichnet, daß der Träger entweder direkt durch Aufstäuben mit einer dünnen Metalloxidschicht oder oben auf einer Schicht oder einem Muster mit den Lichtinterferenzpigmenten und/oder oben auf einer Schicht oder einem Muster mit lichtreflektierenden Pigmenten ohne Lichtinterferenzeigenschaften mit der Metalloxidschicht überzogen ist, wobei darauf geachtet wird, daß die so aufgetragene Metalloxidschicht wesentlich dieselbe Farbe wie die Farbe der mustermäßig angebrachten Pigmente oder eine damit komplementäre Farbe aufweist.

50

22. Dokument nach irgendeinem der vorstehenden Ansprüche, dadurch gekennzeichnet, daß sich an der Vorderseite und/oder der Rückseite des Trägers unter und/oder auf gleichmäßig oder mustermäßig aufgetragenen Interferenzpigmenten ein gedrucktes Guillochestrilmuster mit Regenbogeneffekt befindet, wobei dieses Muster zum Erhalt dieses Effekts lichtreflektierende, den Regenbogeneffekt aufweisende Pigmente enthält, so daß eine oder mehr Regenbogenfarben dieselbe Farbe ist bzw. sind wie die normale oder komplementäre Farbe der Lichtinterferenzpigmente.

55

23. Dokument nach Anspruch 22, dadurch gekennzeichnet, daß eine oder mehr Regenbogenfarben durch Aufdrucken von Metallpigmenten erhalten werden.

24. Dokument nach Anspruch 22, dadurch gekennzeichnet, daß fluoreszierende oder phosphoreszierende Pigmente mit den Lichtinterferenzpigmenten und/oder den lichtreflektierenden Pigmenten vermischt sind und dem Guillochemuster dadurch den Regenbogeneffekt verleihen.
- 5 25. Dokument nach Anspruch 22, dadurch gekennzeichnet, daß der Regenbogeneffekt durch Aufdrucken eines durchsichtigen, mit einem fluoreszierenden oder phosphoreszierenden Pigment geladenen Lacks erhalten wird.
- 10 26. Dokument nach Anspruch 22, dadurch gekennzeichnet, daß (ein) bifluoreszierende(s) Pigment(e) mit einem der lichtreflektierenden Pigmente und/oder mit den Lichtinterferenzpigmenten vermischt ist (sind), wobei das (die) Fluoreszenzpigment(e) bei Belichtung mit Ultraviolettlicht Licht von zwei unterschiedlichen Wellenbereichen aufweist (aufweisen), von denen sich einer bei Betrachtung unter sichtbarem Licht der lichtreflektierenden Pigmente und Lichtinterferenzpigmente vom Wellenbereich der Farben der lichtreflektierenden Pigmente und Lichtinterferenzpigmente unterscheidet und der andere der normalen oder komplementären Farbe der Interferenzpigmente entspricht.
- 15 27. Dokument nach irgendeinem der vorstehenden Ansprüche, dadurch gekennzeichnet, daß ein Guillochemuster mit Regenbogeneffekt in perfektem Durchsichtdruckregister auf der Vorderseite und Rückseite des Trägers gedruckt wird, die an einer Seite gedruckten, lichtreflektierenden, den Regenbogeneffekt aufweisenden Pigmente eine mit der Farbe der gedruckten Pigmente komplementäre Farbe, aber auf einer Seite eine der normalen Farbe der Lichtinterferenzpigmente entsprechende Farbe aufweisen, und Teile des Guillochemusters an beiden Seiten wenigstens teilweise ein Lichtbild oder gedrucktes Muster bedecken oder ein gedrucktes Muster vervollständigen.
- 20 28. Dokument nach irgendeinem der vorstehenden Ansprüche, dadurch gekennzeichnet, daß das Dokument gedruckte Muster, die wenigstens teilweise einander bedecken, und jedes dieser Muster (ein) unterschiedliche(s) Lichtinterferenzpigment(e) enthält, das (die) so strukturiert und zusammengesetzt ist (sind), daß es (sie) bei Betrachtung unter demselben Beobachtungswinkel eine unterschiedliche Farbverschiebung aufweist (aufweisen), und daß das am weitesten vom Beobachter entfernt liegende gedruckte Muster ein höheres Deckvermögen aufweist als das darauf gedruckte, durchsichtigere Muster, wodurch ein Dokument, bei dem unter stufenweiser Änderung des Beobachtungswinkels im überlappenden Musterbereich eine sich ununterbrochen ändernde Farbverschiebung festgestellt wird, erhalten wird.
- 25 29. Dokument nach irgendeinem der vorstehenden Ansprüche, dadurch gekennzeichnet, daß das Dokument in Form eines Laminats vorliegt.
- 30
- 35

Revendications

1. Un document de sécurité qui contient au moins une couche, un support, au moins une image ou un motif servant à des fins d'identification, au moins un pigment d'interférence lumineuse distribué uniformément ou sous forme de motif dans ou sur au moins une couche de ce document, caractérisé en ce que ce support est un support d'un film de résine clair ou un tel support contenant de petites quantités de pigments ou de pores opacifiant le support à un certain degré et possédant une capacité de blocage de lumière visible inférieure à 50 %, et en ce que ce document, suite à la présence de ce pigment d'interférence lumineuse, possède au moins dans certaines zones une couleur différente lorsqu'on l'observe à la lumière transmise par le document par rapport à lorsqu'on l'observe à la lumière réfléchie par le document.
- 40 2. Document selon la revendication 1, caractérisé en ce qu'il contient des mélanges de différents pigments d'interférence lumineuse.
- 50 3. Document selon la revendication 1 ou 2, caractérisé en ce que dans ce document différents pigments d'interférence lumineuse sont chacun présents de manière uniforme dans une couche différente des côtés opposés du support.
- 55 4. Document selon la revendication 1 ou 2, caractérisé en ce que dans ce document différents pigments d'interférence sont chacun présents de manière uniforme dans une couche différente des côtés opposés du support et au moins une de ces couches a au-dessous et/ou au-dessus un motif contenant des pigments et/ou colorants ordinaires réfléchissant la lumière et exempts de propriétés d'interférence lumineuse.

5. Document selon la revendication 4, caractérisé en ce que ce motif a essentiellement la même couleur que la couleur vue en transmission ou en réflexion des pigments d'interférence lumineuse combinés avec ledit motif.
6. Document selon la revendication 1 ou 2, caractérisé en ce que les pigments d'interférence imprimés sous forme de motif sont présents au-dessous et/ou au-dessus d'un motif contenant des pigments et/ou colorants ordinaires réfléchissant la lumière et exempts de propriétés d'interférence lumineuse.
7. Document selon la revendication 1 ou 2, caractérisé en ce qu'un motif de pigments d'interférence imprimés est présent au-dessous et/ou au-dessus d'une couche ou d'un support possédant essentiellement la même couleur que la couleur dudit motif contenant les pigments d'interférence lorsqu'on l'observe en réflexion ou en transmission.
8. Document selon la revendication 1 ou 2, caractérisé en ce que de l'information imprimée contenant les pigments d'interférence lumineuse A au-dessous de laquelle est imprimée de l'information contenant des pigments ordinaires R absorbant et réfléchissant la lumière est présente sur un côté d'un support transparent TS et sur l'autre côté de ce support lesdits pigments ordinaires R sont imprimés dans un motif qui est surimprimé au moins partiellement par un motif contenant des pigments d'interférence lumineuse B.
9. Document selon la revendication 1 ou 2, caractérisé en ce que de l'information contenant des pigments d'interférence lumineuse A sur un côté d'un support transparent TS est imprimée sous forme de motif au-dessus (1) d'un motif R1 de pigment "ordinaire" réfléchissant la lumière dont la couleur est complémentaire à la couleur desdits pigments A lorsqu'on les observe à la lumière réfléchie, (2) d'un motif de pigment comprenant des pigments "ordinaires" R1 réfléchissant la lumière et mélangés avec des colorants ou pigments RF colorés fluorescents ou phosphorescents, et sur l'autre côté dudit support TS des pigments d'interférence B sont imprimés au-dessus (1) d'un motif M de pigment métallique (paillettes d'aluminium ou de bronze), (2) d'un motif comprenant des pigments R2 réfléchissant la lumière avec une couleur complémentaire à la couleur desdits pigments B lorsqu'on les observe à la lumière réfléchie, (3) d'un motif comprenant des pigments métalliques M mélangés avec des pigments "ordinaires" R2 réfléchissant la lumière avec une couleur complémentaire à la couleur desdits pigments B lorsqu'on les observe à la lumière réfléchie.
10. Document selon l'une quelconque des revendications précédentes, caractérisé en ce qu'il contient une image ou un motif obtenu(e) par voie photographique.
11. Document selon la revendication 10, caractérisé en ce que cette image ou ce motif obtenu(e) par voie photographique est produit(e) au moyen d'un halogénure d'argent photosensible développé directement dans un matériau sensible à la lumière ou dans un matériau récepteur d'image non-sensible à la lumière.
12. Document selon la revendication 10, caractérisé en ce que cette image ou ce motif obtenu(e) par voie photographique est produit(e) au moyen d'une technique d'impression sans impact dans laquelle des signaux d'entrée digitaux ou analogues pour commander cette impression proviennent de photosignaux provenant d'un original visible.
13. Document selon la revendication 10, caractérisé en ce que cette image ou ce motif produit(e) par voie photographique est formé(e) par le procédé de transfert de sel d'argent par diffusion dans un matériau récepteur d'image contenant une couche réceptrice d'image comprenant des germes de développement.
14. Document selon la revendication 10, caractérisé en ce que cette image ou ce motif produit(e) par voie photographique est formé(e) par un procédé de transfert de colorant par diffusion dans un matériau récepteur d'image contenant un mordant pour un colorant transféré à partir d'un matériau d'émulsion à l'halogénure d'argent exposé et développé sous forme d'image.
15. Document selon l'une quelconque des revendications précédentes, caractérisé en ce que les pigments d'interférence sont des paillettes mica enduites d'un oxyde métallique.
16. Document selon la revendication 15, caractérisé en ce que l'oxyde métallique est choisi parmi TiO_2 , ZrO_2 , Fe_2O_3 et Cr_2O_3 .
17. Document selon la revendication 15 ou 16, caractérisé en ce que les paillettes enduites de l'oxyde métallique sont recouvertes d'une deuxième couche de carbone.

18. Document selon l'une quelconque des revendications 15 à 17, caractérisé en ce que les paillettes ont un diamètre de surface maximal entre 5 et 200 μm .
- 5 19. Document selon l'une quelconque des revendications 15 à 18, caractérisé en ce que l'épaisseur des pigments d'interférence se situe entre 0,1 et 0,6 μm .
20. Document selon l'une quelconque des revendications précédentes, caractérisé en ce que les pigments d'interférence lumineuse sont présents dans ce document à raison de 0,3 g/m^2 à 10 g/m^2 .
- 10 21. Document selon l'une quelconque des revendications précédentes, caractérisé en ce que le support a été enduit directement par pulvérisation cathodique d'une mince couche d'oxyde métallique ou a été enduit de cette couche d'oxyde métallique au-dessus d'un enduit ou motif desdits pigments d'interférence lumineuse et/ou d'un enduit ou motif de pigments réfléchissant la lumière ne possédant pas de propriétés d'interférence lumineuse, veillant à ce que la couche d'oxyde métallique ainsi appliquée ait essentiellement la même couleur ou une couleur complémentaire à celle des pigments appliqués sous forme de motif.
- 15 22. Document selon l'une quelconque des revendications précédentes, caractérisé en ce que sur le front et/ou le dos dudit support - au-dessous et/ou au-dessus des pigments d'interférence appliqués uniformément ou sous forme de motif - est présent un motif en lignes guillochées avec effet arc-en-ciel qui contient à cette fin des pigments réfléchissant la lumière procurant cet effet de sorte qu'une ou plusieurs des couleurs arc-en-ciel sont identiques à la couleur normale ou complémentaire des pigments d'interférence lumineuse.
- 20 23. Document selon la revendication 22, caractérisé en ce qu'un ou plusieurs des couleurs arc-en-ciel sont obtenus en imprimant des pigments métalliques.
- 25 24. Document selon la revendication 22, caractérisé en ce que des pigments fluorescents ou phosphorescents ont été mélangés avec lesdits pigments d'interférence lumineuse et/ou avec lesdits pigments réfléchissant la lumière procurant cet effet arc-en-ciel au motif guilloché.
- 30 25. Document selon la revendication 22, caractérisé en ce que l'effet arc-en-ciel est obtenu en imprimant un vernis transparent chargé d'un pigment fluorescent ou phosphorescent.
- 35 26. Document selon la revendication 22, caractérisé en ce qu'un ou plusieurs pigments bi-fluorescents sont mélangés avec un des pigments réfléchissant la lumière et/ou mélangés avec les pigments d'interférence lumineuse, ce(s) pigment(s) fluorescent(s) montrant - lorsqu'il(s) est (sont) exposé(s) à la lumière ultraviolette - de la lumière de deux domaines de longueur d'onde différents dont l'un est différent du domaine de longueur d'onde des couleurs desdits pigments d'interférence et réfléchissant la lumière lorsqu'on les observe sous des conditions de lumière visible et l'autre correspond à celui de la couleur normale ou complémentaire desdits pigments d'interférence.
- 40 27. Document selon l'une quelconque des revendications précédentes, caractérisé en ce qu'un motif guilloché avec effet arc-en-ciel est imprimé en parfait registre d'impression translucide sur le front et le dos dudit support, et caractérisé en ce que les pigments réfléchissant la lumière présentant l'effet arc-en-ciel et imprimés sur un côté possèdent une couleur complémentaire par rapport aux pigments imprimés, mais possèdent sur un côté une couleur identique à la couleur normale desdits pigments d'interférence lumineuse, et caractérisé en ce que des parties dudit motif guilloché sur chaque côté recouvrent au moins partiellement une photo ou un motif imprimé ou complètent un motif imprimé.
- 45 28. Document selon l'une quelconque des revendications précédentes, caractérisé en ce que ce document contient des motifs imprimés se chevauchant au moins partiellement et chaque motif contient un ou plusieurs pigments d'interférence lumineuse différents dont la construction et la composition sont telles que les pigments présentent un changement de couleur différent lorsqu'on les observe sous le même angle d'observation, et caractérisé en ce que le motif imprimé qui est le plus éloigné de l'observateur a un pouvoir couvrant plus élevé que le motif imprimé là-dessus qui est plus transparent, obtenant de cette manière un document qui présente dans la zone de chevauchement du motif un changement constant de la couleur en changeant graduellement l'angle d'observation.
- 50 29. Document selon l'une quelconque des revendications précédentes, caractérisé en ce qu'il est sous forme de laminé.
- 55

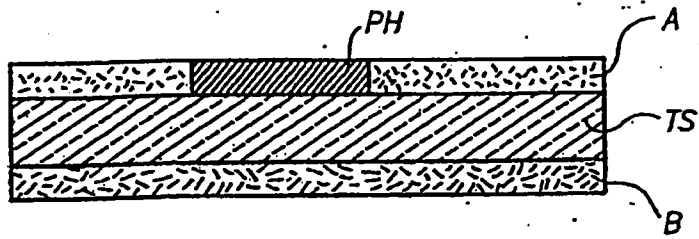

FIG. 1

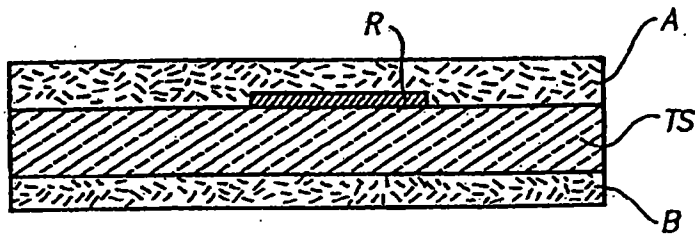

FIG. 2

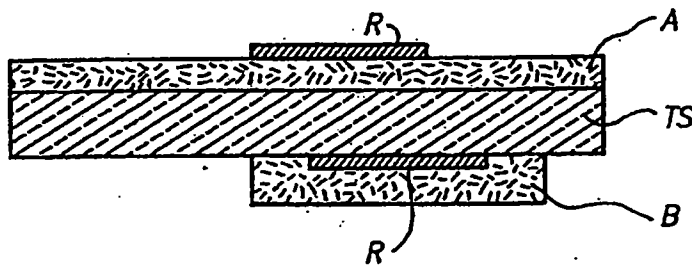

FIG. 3

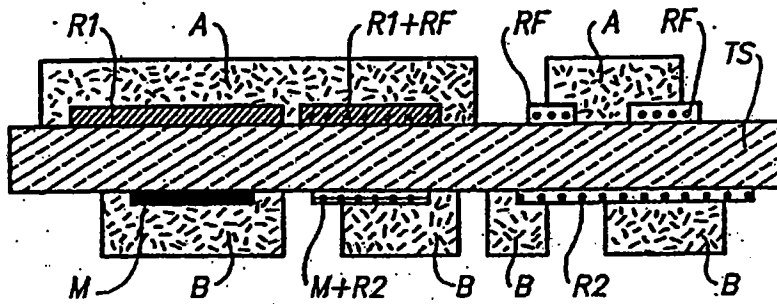

FIG. 4